



CaviBlaster 2570-E

Operation & Maintenance Manual





CAVIDYNE LLC IS NOT RESPONSIBLE FOR DAMAGES OR INJURIES RESULTING FROM A FAILURE TO COMPLY WITH INSTRUCTIONS IN THIS MANUAL. PLEASE READ AND STUDY THE ENTIRE MANUAL CAREFULLY BEFORE USE.



THE CAVIBLASTER MODEL 2570-E MUST ONLY BE OPERATED AND MAINTAINED BY TRAINED PERSONNEL.



THIS EQUIPMENT GENERATES HIGH PRESSURE WATER AND IS INTENDED FOR UNDERWATER USE ONLY. SERIOUS PERSONAL INJURY OR DEATH MAY RESULT FROM IMPROPER USE.



COMMERCIAL DIVER'S GEAR SHOULD BE USED TO OPERATE THE CAVIBLASTER SYSTEM.



ELECTRIC SHOCK CAN CAUSE SEVERE BURNS OR DEATH. GROUND SYSTEM BEFORE CONNECTING POWER SUPPLY. USE DEDICATED CIRCUIT INSTALLED BY A LICENSED ELECTRICIAN. CIRCUIT SHOULD SUPPLY ADEQUATE VOLTAGE AND AMPERAGE UNDER LOAD.



CAUTION: DO NOT USE THIS EQUIPMENT TO CLEAN SENSITIVE SURFACES AS LED-LIGHTS, UNDERWATER LIGHTS, ELECTRONIC EQUIPMENT, ETC.

Unit Specifications:

The CaviBlaster 2570-E power unit consists of a 150HP (100 kW) electric motor and a Lemasa H150/3 triplex plunger pump.

Detailed performance and specifications are listed below:

CaviBlaster 2570-E Specifications	
Nominal Pump Flow	29 GPM (110 LPM)
Nozzle Operating Pressure	7,000 PSI (483 BAR)
Motor	150 HP 3 PHASE 460 Volts @ 60Hz 58.5 Amp
Installation Environment	Indoor or Outdoor <i>See Section 4 for installation requirements</i>
Water Inlet Pressure Limits	0 PSI (Atmospheric Pressure) to 50 PSI Maximum (0 BAR to 3.5 BAR) <i>See Section 4 for further requirements</i>
Overall Unit Dimensions (L x W x H)	63" x 47" x 50" (166 cm x 119 cm x 127 cm)
Maximum Pressure Hose Length	600 LF (200 meters) of 3/4" diameter
Power Unit Weight (Dry)	4500 LBS (2042 KG)
Zero-Thrust Gun Weight	4.4 LBS (2 KG)

Figure 1.1 – CaviBlaster 2570-E Specifications

General Description:

The CaviBlaster 2570-E high-pressure waterpower unit is designed to use water flow and pressure to generate cavitation at the end of the proprietary nozzle.

The CaviBlaster cleans the surface of any underwater structure using the energy released by the implosion of the bubbles created during the cavitation process. When directed at the surface being cleaned, the energy released by the collapsing bubbles causes marine growth to be removed from the surface.

The system consists of a portable, zero-thrust gun, connecting high-pressure hose and an electric motor-powered, high-pressure pumping unit. The zero-thrust gun uses a trigger-operated valve to control the water stream off and on. If the valve is closed, the power unit goes into bypass mode unloading the engine and the pump.

The CaviBlaster 2570-E power unit is a complete “plug and play” system built into a self-supporting frame that allows quick deployment and/or installation of the unit. Water can be supplied from either a pressurized source, directly from the natural source via an electric feed pump supplied with the power unit, or from a gravity feed storage tank.

The unit is equipped with many features to maintain operator safety while operating at pressures of 7,000 psi (483 BAR) with safety overload protection rating to 10,000 psi (690 BAR).

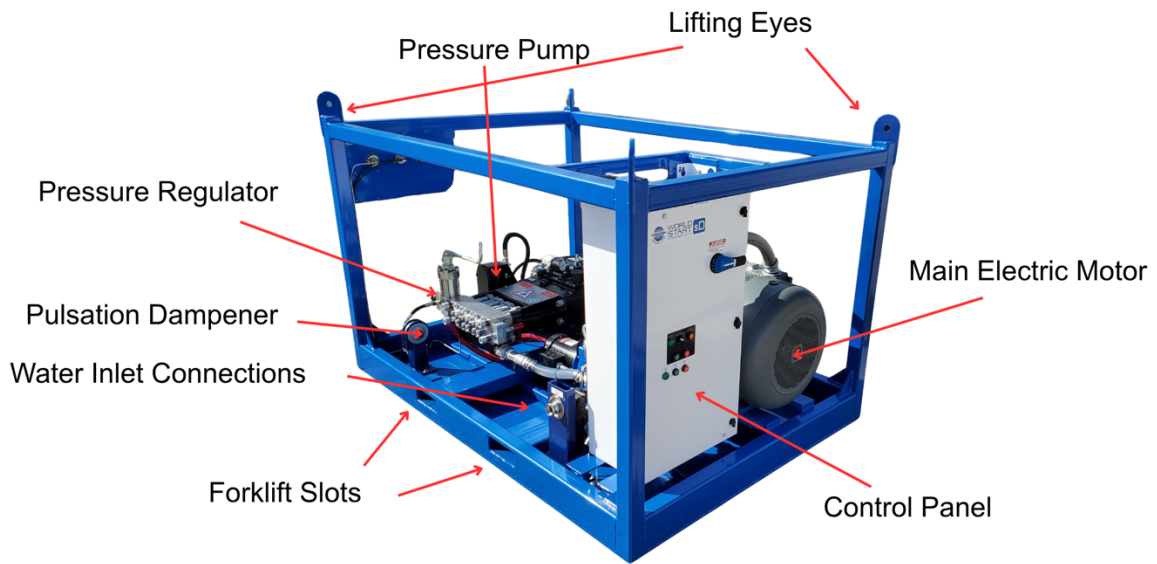

Figure 2.1 – CaviBlaster 2570-E General Features



Pressure Gauges

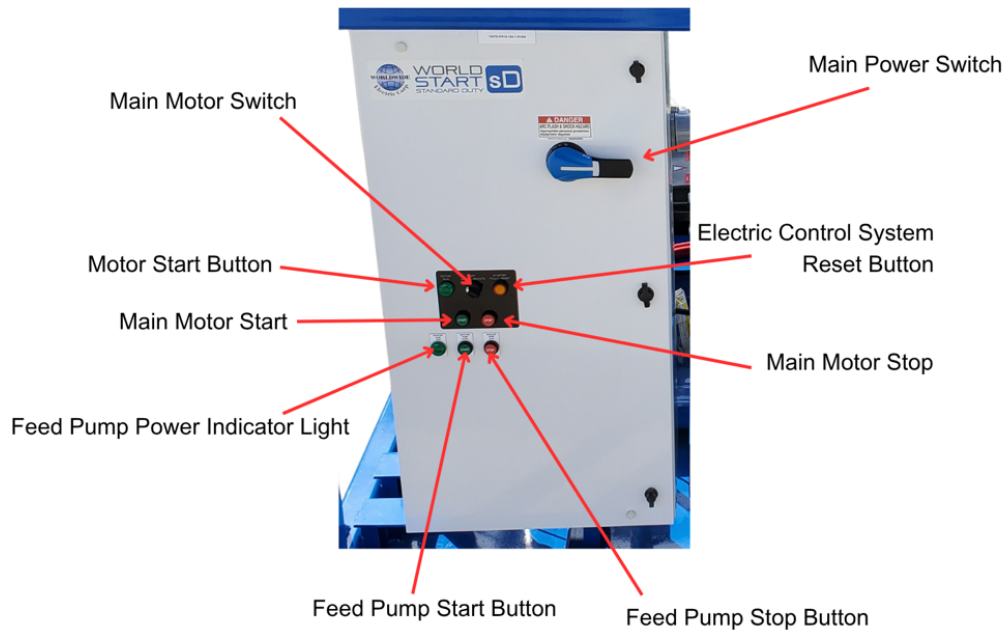

Figure 2.2 – CaviBlaster 2570-E Control Panel

Using This Manual:

While every effort has been made to ensure the accuracy and completeness of the content of this documentation, CaviDyne, LLC, its employees or associated organizations shall have neither liability nor responsibility to any person or entity with respect to any loss or damage arising from its use. Always take appropriate and adequate precautions to prevent damage or injury. Should you, at any time, have questions or concerns, please, contact our headquarters, as we will be happy to assist you. While quality and your satisfaction are our goal, nothing takes precedence over your safety.

Safety Information:

The CaviBlaster 2570-E Power Unit is an inherently powerful and potentially dangerous piece of equipment; however, with proper care and training it can be operated safely. The 2570-E must only be operated by personnel that have read and understand this manual. It is intended to reinforce and review safety techniques to prevent personal injuries and property damage.

Users must comply with all local, state, and national laws concerning high-pressure water jetting equipment as well as all underwater work regulations.

It is strongly recommended that this entire manual be reviewed in-depth before operating or servicing this equipment. Service work should only be performed by individuals who are proficient in using this equipment. Refer to the applicable section in this manual for the correct procedures prior to any installation, setup, or maintenance work.

Personal Safety

Operation of the CaviBlaster 2570-E underwater cleaning system must only be attempted by commercial divers or other personnel who have been trained in its use. Appropriate protective equipment should always be worn. Operation of the system without the proper equipment and training can result in personal injury.



CAVIDYNE, LLC IS NOT RESPONSIBLE FOR DAMAGES OR INJURIES RESULTING FROM A FAILURE TO COMPLY WITH INSTRUCTIONS IN THIS MANUAL. PLEASE READ AND STUDY THE ENTIRE MANUAL CAREFULLY BEFORE USE.



IF MAINTENANCE OR REPAIR OF THE CAVIBLASTER GUN IS BEING CONDUCTED OUT OF THE WATER, REMEMBER THAT THE ZERO- THRUST GUN HAS FRONT AND REAR JETS. NEVER DIRECT THE JET STREAMS AT A PERSON OR ANIMAL, OR TOWARD POWER LINES OR OTHER HIGH VOLTAGE EQUIPMENT.



ENSURE THAT THERE IS A SAFE AREA TO WORK WHILE OPERATING THE CAVIBLASTER 2570-E.



SEEK IMMEDIATE MEDICAL ATTENTION IF THE OPERATOR SUFFERS AN INJURY AS THE RESULT OF CONTACT WITH THE HIGH-PRESSURE WATER STREAM. SERIOUS PERSONAL INJURY CAN RESULT FROM AN UNTREATED WATER INJECTION WOUND.

Personal Protective Equipment:

Always wear appropriate Personal Protective Equipment (PPE) when operating this equipment.

Personnel operating or working in the vicinity of the power unit should wear appropriate hearing protection when the CaviBlaster system is in use. If the diver is not wearing a diving helmet, hearing protection is recommended. CaviDyne, LLC recommends wearing vented earplugs such as "Doc's Pro-plugs" for diver hearing protection.

The operators of the CaviBlaster system should always wear neoprene or heavy rubber gloves to provide protection to the hands and nails. The gloves will absorb most of the energy produced by bursting cavitation bubbles and prevent the cavitation bubbles from contacting the operators' hands. The gloves will also protect operators' hands from the initial shock wave when the Z/T-Gun / CaviDome is activated.



FAILURE TO WEAR APPROPRIATE PPE MAY RESULT IN PERSONAL INJURY.

Modifications:

Do not make any unauthorized modifications or repairs to this equipment. Components used throughout this assembly were specifically designed or selected to safely meet the unique high-pressure requirements. Only replace parts with those recommended by or supplied by CaviDyne, LLC. Any unapproved modifications will void the equipment warranty. Unauthorized modification or part substitution can result in serious personal injury or property damage.



UNAUTHORIZED REPLACEMENT OF ANY PART MAY LEAD TO CATASTROPHIC EQUIPMENT FAILURE AND SERIOUS PERSONAL INJURY.



USE OF GUNS OR PRESSURE NOZZLES OTHER THAN THOSE SUPPLIED OR SPECIFIED BY THE MANUFACTURER MAY LEAD TO CATASTROPHIC EQUIPMENT FAILURE AND SERIOUS PERSONAL INJURY.

Installation:

The CaviBlaster 2570-E must be installed in accordance with the requirements outlined below. The unit can be installed in a vehicle to allow for maximum mobility and flexibility.

Uncrating and Lifting:

Unpack the equipment and inspect for damage. If damage is found, immediately contact CAVIDYNE and the shipping company. *If the unit will not be installed immediately, provide adequate indoor storage to protect against damage.* **If there are missing parts/spare parts, contact freight carrier or insurance company.**

The CaviBlaster power unit should be lifted from underneath the frame using the forklift channels or by using the lifting eyes provided on top of the frame. Verify that lifting equipment is rated for the weight listed in **Section 1.0 UNIT SPECIFICATIONS** and that the unit is stable before lifting.

Lift Unit from Top of the Frame Using the Lifting Eyes

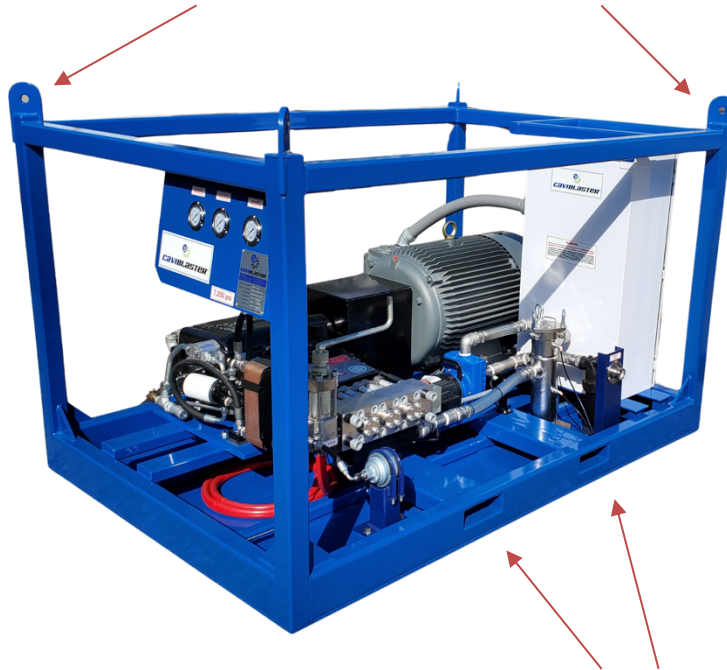

Lift Unit from Underneath the Frame Using the Forklift Slots

Figure 4.1 – Lifting Guidelines

Installation Location:

For maximum flexibility, the CaviBlaster Power Unit should be installed in an area where it can reach both its water source and anticipated cleaning targets within acceptable hose lengths. The CaviBlaster Power Unit can be installed in an enclosed or open environment.

** Enclosed installations will require provisions for adequate motor cooling air flow. See **Figure 4.2** below.*

Installation location must be a level surface able to safely support the unit weight listed in **Section 1.0 UNIT SPECIFICATIONS**. Position the unit to allow unrestricted access to the hose connection plate and control panel, located on the front of the unit. Allow a minimum of three feet behind the unit and access from above to conduct service and repair work. Take note of frequently serviced areas such as the in-line strainers and motor couplings.



Allow Access for General Service
Allow Access to the Hose Connections Panel
Allow Access to the Electric Panel



Figure 4.2 – Installation Guidelines

Initial Set-Up:

After first receiving the CaviBlaster Power Unit, the following must be checked and completed:

1. Check / add pump oil (See **Pump Manual**).
2. Push in the Emergency Motor Shut Off (E-Stop) button.
3. Turn the main power to the OFF position.
4. Turn the HPP motor switch, SW1, to the “OFF” position.
5. Turn the feed pump switch, SW2, to the “OFF” position.
6. Connect the power cable (not provided) for the unit to the power source.
7. Confirm correct rotation of Feed Pump Unit. Reverse power cable wiring to achieve correct rotation.
8. Close and lock the control panel door.
9. Connect the feed or suction hose (See **Section 4.3.2**).
10. Connect the bypass hose (See **Figure 2.2**).
11. Connect the pressure hose (See **Figure 2.2**).



ENGINE AND/OR PUMP FLUIDS MAY HAVE BEEN REMOVED FOR SHIPMENT. CHECK FLUID LEVELS PRIOR TO STARTING.

Connecting the Water Source:

The CaviBlaster Power Unit can be used with seawater or fresh water. It must be flushed with fresh water for 1-2 minutes after each use in seawater to ensure long service life.

An electric boost pump is installed to provide positive inlet water pressure to the main pressure pump. The Power Unit incorporates a high-flow centrifugal feed pump to support the main pump system. The feed pump can provide 50-70 GPM of water for the system.

Priming the System Using the Feed Pump System:

Attention to priming the system is necessary. The feed water suction hose inlet connection is located on the water connection panel (See **Figure 2.2**). The (clear) suction hose should be straight and at a slight downward angle from the inlet connection on the water connection panel, with no “humps” in the hose so that trapping of air pockets and creating an air lock is minimized. During the priming cycle the suction hose should always remain below the height of the inlet connection unless connecting with a positive pressure water source.

NOTE: Assure that no air is trapped in the feed hose to cause an air lock leading to the feed pump.

The feed pump system is fully capable of self-priming. The feed pump should be charged with water to more effectively draw from the source. It is suggested a positive pressure water source be utilized to initially charge the feed pump system.

NOTE: The feed pump may require upwards of 5-7 minutes to draw sufficient water to prime the system before starting the main pump system.

Once fully primed should a restart be needed, confirm priming is complete, without trapped air pockets.

Water Supply Conditions:

- Forced inlet water condition using the supplied electric water pump.
- An outside water source capable of supplying a minimum of 40 GPM (150 LPM) at a **maximum pressure of 50-PSI (3.5 BAR)**.
- Gravity feeding water source (See Figure 4.3). Use a hose with a diameter of at least 1-1/2” to connect the water tank to the power unit water inlet.

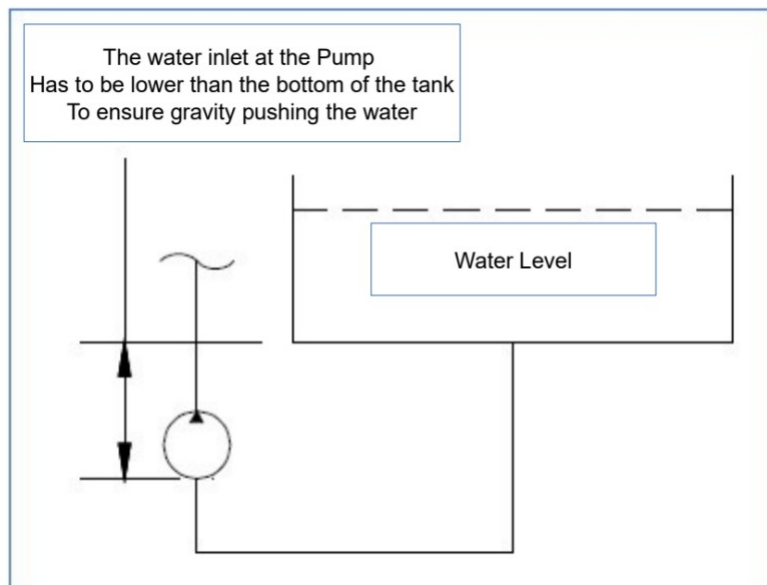

Figure 4.3 – Gravity Feeding Source

Using the Feed Pump System:

1. Verify the main power switch, HPP motor switch and feed pump motor are switched to "OFF."
2. Ensure the E-Stop button is pushed "IN" so that the power supply has been disconnected. (See **Figure 2.2**).
3. Connect the cam-lock socket on the 1-1/2" clear PVC feed hose to the water inlet connection on the control panel (See **Figure 2.2**). Place the other end of the hose in the water supply.

NOTE: the pump system must be fully primed before starting the HPP Pump or serious damage to HPP Pump will occur. Refer to **Section 4.3.2** (above) for priming instructions.

Using Force Feed Supply from an Alternate Source:

1. Verify the main power switch, HPP motor switch and feed pump motor are switched to "OFF."
2. Ensure the E-Stop button is pushed "IN" so that the power supply has been disconnected (See **Figure 2.2**).
3. When feeding the CaviBlaster with an alternate water source, the source must be capable to supply water at a volume of greater than 28 GPM (106 LPM) at a maximum pressure of 50-PSI.
4. Connect a 1-1/2" cam-lock socket on the water supply hose to the water inlet connection on the control panel (See **Figure 2.2**). Confirm system is primed.

To Use Gravity Feed:

1. Locate the water supply tank so that the outlet of the supply tank is higher than the water inlet on the control panel (See **Figures 2.2 and 4.3**).
2. Verify the main power switch, HPP motor switch and feed pump motor are switched to "OFF."
3. Ensure the E-Stop button is pushed "IN" so that the power supply has been disconnected (See **Figure 2.2**).
4. Connect a hose (minimum 1-1/2" diameter) to the water inlet (1-1/2" cam-lock plug). Connect the other end of the hose to the water supply tank outlet.
5. Open any valves installed in the water supply line.
6. Make sure the lowest point in the hose line is the connection with the power unit.

NOTE: The pump system must be fully primed before starting the HPP Pump or serious damage to HPP Pump will occur. Refer to **Section 4.3.2** above for priming instructions.

It is essential that adequate water is supplied to the water supply tank to maintain the water level several inches above the tank outlet. Failure to maintain an adequate water level in the supply tank during operation could starve the pressure pump of water causing damage to the seals or other components of the pressure pump.

Ensure that the water source can reliably deliver the maximum pump flow of 30 GPM (115 LPM). A minimum flow of 40 GPM (150 LPM) is recommended to ensure that the pump is not starved of water. If connecting to a gravity feed tank, locate the tank outlet above the water inlet connection on the power unit to ensure a flooded suction line. (See Figure 4.3).



ENSURE THAT THE FEED HOSE IS CONNECTED TO THE INLET CONNECTION AND THE WATER SUPPLY IS ON PRIOR TO STARTING THE PRESSURE PUMP. FAILURE TO SUPPLY WATER TO THE PRESSURE PUMP WILL CAUSE DAMAGE TO THE PUMP.

Operation:

The CaviBlaster 2570-E should be operated by two (2) properly trained individuals. One, the diver, operates the zero-thrust gun, while the other operates the power unit. Both operators should be in audio or visual communication with each other.



THE CAVIBLASTER 2570-E SHOULD ONLY BE OPERATED BY PROPERLY TRAINED PERSONNEL WHO ARE FAMILIAR WITH THE CONTENTS OF THE MANUAL. REVIEW THE SAFETY REQUIREMENTS FOUND IN SECTION 3.0 BEFORE OPERATING.

Preparing the Unit for Operation:

The following checklist should be completed in advance, so that the unit is always ready for immediate use. This should be completed after each use.

1. Inspect the CaviBlaster Power Unit, electric power cord, hoses, JIC fittings and zero-thrust gun for any signs of damage.
2. Check that the motor is clean, and ventilation openings are clear.
3. Inspect the inline strainer to ensure that it is not clogged (See **Figure 6.1**). Clean if necessary.
4. Check for proper pressure pump oil level (See **Pump Owner's Manual**). Add lubricating oil (SAE 30 non-detergent) if necessary.

Startup of the CaviBlaster:

Before starting the CaviBlaster 2570-E power unit, review all safety requirements found in **Section 3.0 SAFETY INFORMATION**. This equipment should only be operated by individuals who have read and understand the CaviBlaster Operation and Maintenance Manual.

1. Verify that the unit has been properly prepared for operation as described in **Section 4**.
2. Unroll sufficient length of hose to reach the operating location and connect the gun to the high-pressure hose
3. Turn the E-Stop button and pull out to release (See **Figure 5.1**).

4. Turn the main power switch “ON.”
5. Turn the feed pump switch, SW2, “ON” and wait for the indicator light to turn on.
6. Turn the HPP motor switch, SW1, “ON” and wait for the indicator light to turn on. Note that the motor is equipped with a “soft start” starter and takes 3-4 seconds for the motor to start after being turned “ON.”
7. When the diver is ready to commence cleaning operations, ensure that the system is properly and fully primed and the diver gun is submerged in water. If the diver is not wearing a helmet, hearing protection is recommended. CaviDyne, LLC. suggests vented earplugs such as “Doc’s Proplugs” for diver hearing protection.
8. **Wear neoprene or rubber gloves to protect the hands and follow all safety regulations that may be applicable to the work being performed.**
9. Pull the gun trigger to the open or “ON” position (See **Figure 5.3**).
10. The system is now ready to operate.



DO NOT THROTTLE UP THE ENGINE UNTIL THE DIVER IS READY FOR UNDERWATER OPERATION.

Normal Operation:

Normal operation of the CaviBlaster system is defined as user control of water flow via the gun trigger. Control of the power unit from the gun trigger is accomplished by a mechanical shut-off valve in the gun. Should a problem develop with the control valve, discontinue using the CaviBlaster until fixed.



REVIEW THE SAFETY REQUIREMENTS FOR PPE AND SAFE OPERATION BEFORE PROCEEDING.

1. Startup the power unit as described in **Section 5.2**.
2. Activate the cleaning cavitation stream by squeezing the trigger to the open or “ON” position (See **Figure 5.3**). Release trigger to stop the water flow and direct to bypass.
3. If the diver operating the unit must be replaced or the cleaning operation must be interrupted or terminated, turn the unit off and then release the water pressure in the hose(s) by squeezing the gun trigger to the open or “ON” position (See **Figure 5.3**) while under water. Revert to step 5.2 of the operating instructions when the diver or replacement is ready to continue cleaning.



ALTHOUGH THE CAVIBLASTER SYSTEM IS SAFE TO USE WHEN SUBMERGED IN WATER, THE SYSTEM GENERATES A HIGH-PRESSURE (UP TO 7,000 PSI {483 BAR}) WATER STREAM, WHICH CAN CAUSE INJURY WHEN THE GUN IS OUT OF THE WATER. ALWAYS KEEP THE GUN SUBMERGED WHEN THE PRESSURE PUMP IS RUNNING.

Adjusting the CaviBlaster for Maximum Performance

The pressure at the nozzle of the zero-thrust gun must be maintained within certain limits to achieve cavitation and for best performance results. Using a calibration pressure gauge tool situated between the pressure hose and the CaviBlaster zero-thrust gun, (See **Figure 5.2**) the water pressure should be 7,000 psi (483 BAR) with the gun submerged and the gun trigger in the open or “ON” position. For best results, repeat this calibration procedure if cleaning performance degrades, or every 3 months at a minimum.



A CALIBRATION GAUGE IS RECOMMENDED WITH EVERY UNIT. CONNECT BETWEEN THE MAIN PRESSURE HOSE AND THE WHIP HOSE OR ZERO-THRUST GUN. SEE FIGURE 5.2.

To Calibrate the Pressure at the Zero-Thrust Gun, Follow the Procedure Below:

1. Stop the Power Unit and pull the gun trigger to discharge any residual pressure in the hose lines.
2. Disconnect the gun with its whip hose from the main pressure hose line.
3. Attach the calibration gauge to the main pressure hose line and attach the whip hose to the pressure gage. Tighten the JIC connections.
4. Submerge the gun because of the danger of the operator encountering either of the water streams from the cavitating or zero-thrust nozzles, CaviDyne does NOT recommend calibrating the gun out of the water. Use extra care to avoid both water streams if doing so.
5. Ensure that both the cavitation and zero-thrust nozzles are pointed away from the diver's or operator's hands, arms and body.
6. Start the Power Unit (See Section 5.2).
7. Keep the gun trigger in the closed or “OFF” position (See Figure 5.3).
8. Wait until the motor fully completes its “in rush” stage.
9. Pull the gun trigger to open “ON” position
10. Hold the gun tight and observe the calibration gauge (See Figure 5.2).
11. The Power Unit operator should turn the knob on top of the pressure regulating valve until pressure reads 7,200-PSI (500 BAR) on the calibration gauge at the Z/T Gun. Turning the knob clockwise will increase the pressure and turning it counterclockwise will decrease the pressure.



DO NOT ADJUST THE PRESSURE AT THE ZERO-THRUST GUN TO MORE THAN 7,000-PSI (483 BAR). HIGHER PRESSURE WILL NOT IMPROVE PERFORMANCE.



HOSE LINES ARE RATED FOR 10,000-PSI (690 BAR). PRESSURES ABOVE 7,000-PSI (483 BAR) COULD RESULT IN PUMP AND / OR HOSE FAILURE.

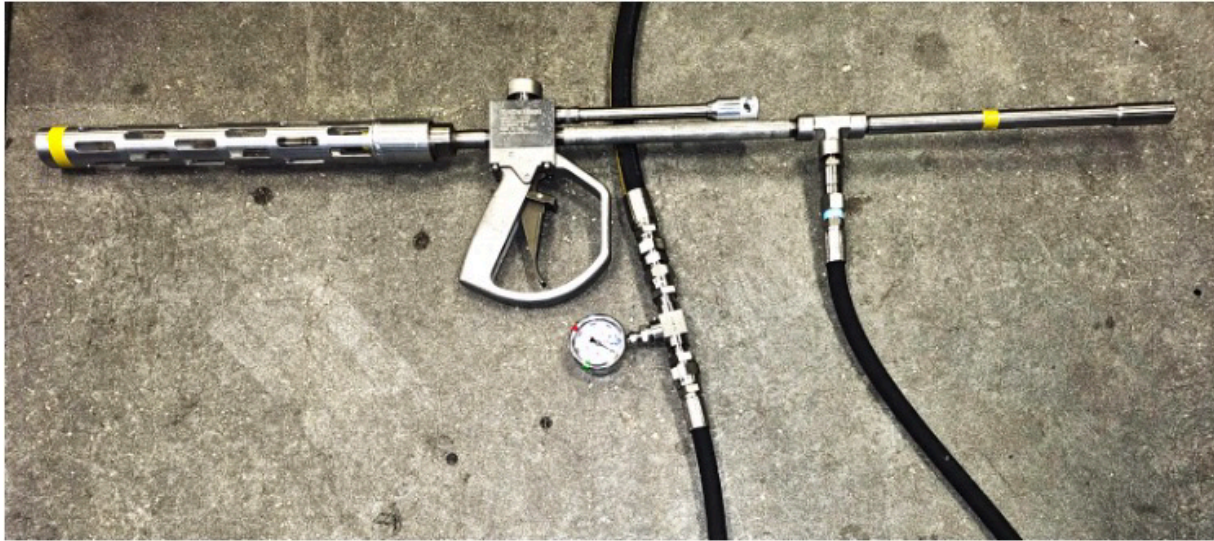

Figure 5.1 – Zero-Thrust Gun Pressure Calibration

Recommendations for Effective Results:

Once the unit is operating at normal speed and the zero-thrust gun trigger is pulled, the diver must find the most effective distance between the zero-thrust gun nozzle and the surface being cleaned.

When the diver is ready to commence cleaning operations, ensure that the zero-thrust gun trigger is in the open or “ON” position (See **Figure 5.3**), the zero-thrust gun is submerged in the water, and the feed pump is operating prior to starting the electric motor. Ensure that the power unit operator and other people working in the vicinity of the power unit wear appropriate hearing protection when the unit is running.

1. Engage the pressure pump by turning the start-up by-pass valve to the “CLOSED” position (See **Figure 5.1**).
2. The most efficient operating technique is to hold the nozzle 2-5 inches (5-12 cm) away from the surface to be cleaned and at a 25-to-45-degree angle to the surface being cleaned (See **Figure 5.3**). The diver needs to observe the shape of the cavitating jet cone. At greater depths, the higher ambient pressure will cause the jet cone to be shorter. The widest zone of the cone is the most efficient part of the cavitating jet. Placing the nozzle closer than 2 inches (5 cm) from the surface being cleaned will not allow for efficient cavitation performance and will degrade the cleaning capability of the CaviBlaster system.
3. Follow all safety regulations that may be applicable to the work being performed.

4. If the diver operating the unit must be replaced or the cleaning operation must be interrupted or terminated, turn the unit off and then release the water pressure in the hose(s) by squeezing the gun trigger to the open or “ON” position (See **Figure 5.3**) while under water. Revert to step 5.2 of the operating instructions when the diver or replacement is ready to continue cleaning.

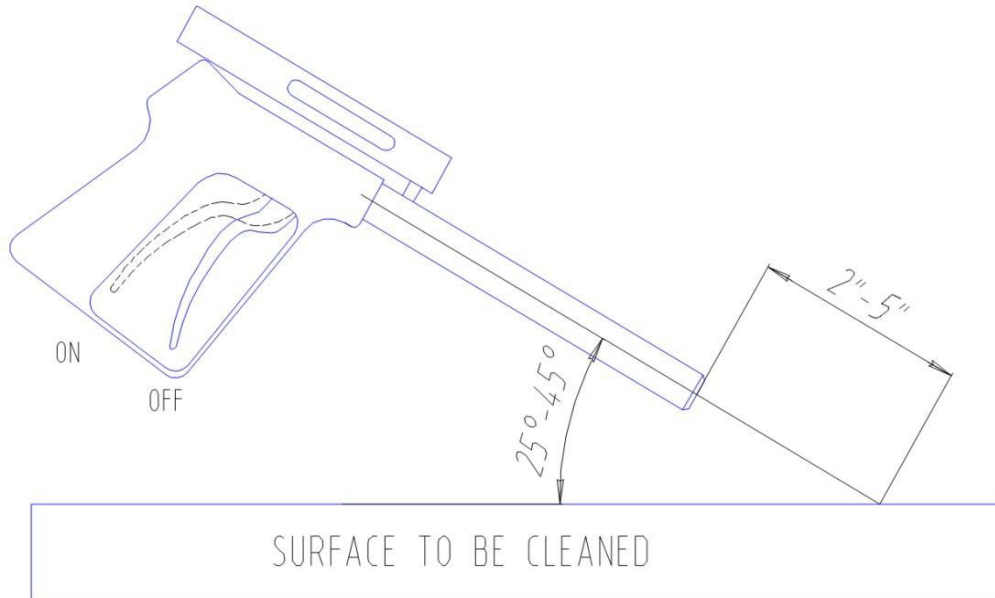

Figure 5.2 – Zero-Thrust Gun Position for Best Results

Shutting Down the CaviBlaster:

1. Stop the motor by turning the HPP motor switch, SW1, to the OFF position (See **Figure 2.2**).
2. Turn the feed pump switch, SW2, to the “OFF” position (See **Figure 2.2**). If using force feed from an alternate source or if using gravity feed, shut off the supply of water to the pressure pump.
3. Turn the main switch to the “OFF” position.
4. Push in the E-Stop button.
5. Squeeze the gun trigger to the open or “ON” position (See **Figure 5.3**) to release the water pressure remaining in the hose(s) while the gun is submerged.
6. It is now safe to remove the gun from the water.
7. Flush the system and rinse the power unit with fresh water at the end of the day if the system has been used with seawater.

Maintenance:

Maintenance on this unit should be restricted to authorized personal that have been properly trained. Review this manual, especially **Section 3.0 SAFETY INFORMATION**, prior to performing any service on this equipment.



EQUIPMENT MUST BE “OFF” AND PRESSURE RELEASED FROM ALL HOSES PRIOR TO ANY SERVICE WORK.



ONLY REPLACE PARTS WITH THOSE SUPPLIED OR APPROVED BY CAVIDYNE, LLC. USE OF ANY OTHER PARTS MAY LEAD TO EQUIPMENT FAILURE AND SEVERE PERSONAL INJURY



THE CAVIBLASTER 2570-E MUST BE FLUSHED AND RINSED AFTER EACH USE IN SEA WATER.



FAILURE TO FLUSH AND RINSE THE UNIT WILL RESULT IN PREMATURE WEAR AND TEAR ON THE COMPONENTS AND DECREASED SERVICE LIFE.



FAILURE TO FLUSH AND RINSE THE UNIT CAN CAUSE THE PUMP VALVE(S) TO STICK IN THE OPEN POSITION. THIS WILL PREVENT THE SYSTEM FROM PRODUCING THE CORRECT OPERATING PRESSURE.

Basic Preventive Maintenance Recommendations

Task	Before and After Every Use	Every 6 Months or 125 Hours*	Every 6 Months or 500 Hours*	Every 12 Months or 500 Hours*	Every 1,000 Hours	Every 4 Years or 7,500 Hours*
Check pump oil level and add if low	X					
Check in-line strainer cartridge and clean if necessary	X					
Inspect hoses for wear or damage ¹	X					
Check gun trigger for leakage and repair if necessary ²		X				
Check integrity of motor winding insulation with "megger" test			X			
Replace pump oil ³				X		
Check pump valves and seals for wear & change if necessary					X	
Lubricate motor bearings with high grade ball or roller bearing grease						X

* Whichever occurs first.

- 1) If any hose damage is found, replace hose immediately.
- 2) Remove gun from water with system at operating pressure and trigger in the closed or "OFF" position. If water is leaking out of barrel or handle, the gun trigger valve is worn and should be replaced.
- 3) The initial oil change is after 50 hours of operation. See pump manufacturer's literature in the Appendix for additional recommendations.

Pump Service:

The high-pressure water pump requires minimal maintenance. The pump oil level should be checked on a regular basis. The pump crankcase with Gear box holds 9 liters (304 US fluid ounce), of SAE 80W 90 viscosity non-detergent oil.

Inspection/Cleaning of Water Inlet Strainer:

The water inlet strainer and the water filter should be inspected before and after each use of the CaviBlaster 2570-E. To inspect and clean the strainer or filter, follow the procedure below:

1. Turn the main power switch “OFF” and isolate or disconnect the water source from the inlet connection to the power unit.
2. Unscrew the strainer bowl from the housing (turn counterclockwise) (See **Figure 6.1**).
3. Pull the bowl down and remove the filter/strainer.
4. Inspect the filter/strainer and flush any debris clean with clean water.
5. Push filter/strainer back into housing and push the bowl back onto filter housing.
6. Thread the bowl clockwise onto the housing nut to hand tighten.
7. Loosen and remove cap of main filter assy.
8. Lift filter media from housing and inspect for debris. Rinse or replace media as necessary.
9. Inspect O-ring under the cap for damage. Replace cap and tighten.

Inlet Filter

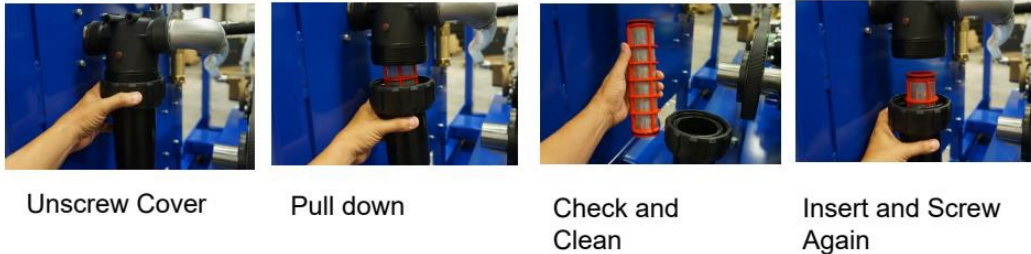

Main Filter

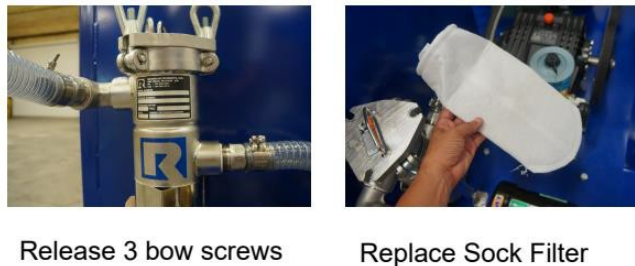

Figure 6.1 – Inspection / Cleaning Water Filter / Strainer

Inspection / Maintenance of the Zero-Thrust Gun:

To minimize potential problems with the Zero-Thrust Gun it is recommended that the gun be inspected and maintained at the end of each work period:

1. Flush and rinse the gun with fresh water after each use in sea water.
2. If the unit will be used in the next 24 hours, place the gun in a container of clean, fresh water. Ensure the gun is completely submerged.
3. If the gun will not be used for a period of several days, flush the gun as noted, remove the whip hose from the super swivel. With the gun turned upside down, pour approx. 5ml of lubricating oil into the water inlet of the gun while opening and closing the trigger to allow oil to reach the positioning pin and valve cone. This will minimize the possibility of corrosion or mineral crystals from forming that would freeze the pin or valve cone.
4. Do not use WD-40 for long term storage.

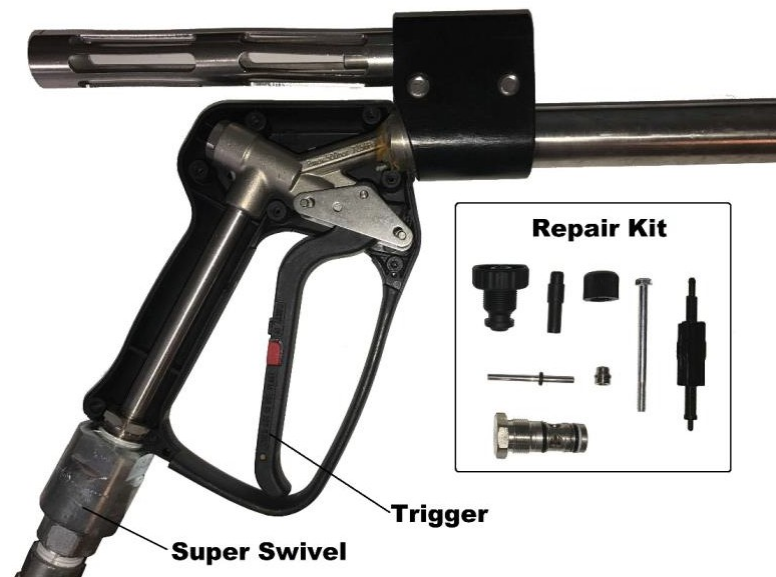

Figure 6.2 – Zero-Thrust Gun

Winterization:

The power unit should be winterized if stored at temperatures below 32 degrees Fahrenheit (0 degrees Celsius).

Total system displacement with 100 ft. of hose (optional): **4.3 gallons**

Total system displacement without hose: **2.0 gallons**

To winterize the CaviBlaster 2570-E Power Unit:

1. Fill a 5 gallon (19 liter) or larger container with appropriate antifreeze solution.
2. Connect a 1-1/2" cam-lock socket with a minimum amount of 1-1/2" clear hose to the water inlet connection on the control panel (See **Figure 2.2**) and place the open end of the clear hose into the antifreeze solution.
3. Attach a minimal amount of pressure hose to the pressure connection on the control panel (See **Figure 2.2**) and direct the open outlet of the hose into the antifreeze tank.
4. Attach a minimum amount of hose to the start-up by-pass valve and place the open end into the antifreeze tank.
5. Open the start-up by-pass valve and start the unit and make sure the pump is primed.
6. Close the start-up by-pass valve and run the unit until antifreeze comes out of the open end of the pressure hose for 10 seconds.
7. Stop the unit and disconnect all hoses.

Following this procedure will ensure that all the critical system components exposed to water have been flushed with antifreeze.

Troubleshooting:

MOTOR WILL NOT START

- Make sure "Emergency Stop" is not engaged
- Make sure all three phases are live, and the ground circuit is complete
- Check circuit breakers to make sure they are set "on"
- Check master disconnects to ensure that it is "on"

MOTOR HUMS EXCESSIVELY

- Check input line connections for proper voltage
- Check motor contactor for proper

MOTOR OVERHEATS

- Overload – compare actual (measured) amps with nameplate rating Locate and remove source of excessive friction in motor or load
- Single phasing – check current at all phases (should be approximately equal to isolate and correct the problem
- Improper ventilation
 - Check external cooling fan to ensure air is moving across cooling fins Excessive dirt build-up on motor – clean motor
- Unbalanced voltage - check voltage at all phases (should be approximately equal to isolate

- and correct the problem
- Rotor rubbing on stator
 - Check air gap clearance and bearings
 - Tighten “thru bolts”
- Over voltage or under voltage – check input voltage at each phase
- Open stator winding – check stator balance at all phases for balance
- Grounded winding – perform dielectric test and repair
- Improper connections – inspect all connections for proper termination, clearance, mechanical strength and electrical continuity

BEARING OVERHEATS

- Misalignment – check and align motor and pump
- Excessive end thrust from pump
- Excessive or insufficient grease in bearing – cavity should be $\frac{3}{4}$ filled
- Dirt in bearing – clean bearing and cavity and refill approximately $\frac{3}{4}$ full

VIBRATION

- Misalignment – check and align motor and pump
- Rubbing between rotating and stationary parts
- Rotor out of balance
- Resonance – tune system

GROWLING OR WHINING

- Bad bearing – replace bearing and repack with correct grease

MOTOR RUNS, BUT WATER DOES NOT COME OUT OF THE GUN

- Verify inlet water supply is functioning
- Ensure that the power unit is not located too far above the water level, exceeding the capacity of the feed pump
- Check that feed pump and inlet water strainers are clear
- Check for leaks in the water lines
- Check for an airlock in the water inlet lines
- Verify that the feed pump is delivering water
 - Pump mechanical failure
 - Bad electrical connections
- Check that pressure pump inlet and discharge valves are not stuck open (common problem if not flushed after use with sea water)
- Check for water going out of the bypass – regulating unloader failure

WATER IN CRANK CASE

- Check the pump seals for damage (feeding water at greater than 50-PSI (3.4 BAR) can force water past the seals and damage the seals and starving the pressure pump of water can overheat and damage the seals)
- Check the plungers for cracks
- Check the plunger rod O-ring for damage

AFTER RELEASING THE MECHANICAL TRIGGER, WATER IS STILL LEAKING OUT OF THE GUN

- Replace the mechanical trigger valve assembly in the gun handle

ZERO-THRUST GUN IS NOT CLEANING PROPERLY

- Verify that the system is operating at the correct pressure (4,000-PSI; 276 BAR).
- Remove the zero-thrust gun from the water with the system at operating pressure and trigger in the closed or “OFF” position. If water is leaking out of the barrel or handle, the trigger valve assembly should be replaced.
- Check cavitation and zero-thrust nozzles for foreign particles
- Visual inspection
 - With the unit turned “OFF”, insert a small wire into nozzle orifices to check for obstruction(s)
 - Remove trigger valve assembly and “backflush” with compressed air or pressurized water

Replacement Parts:

CaviBlaster 2570-E POWER UNIT REPLACEMENT PARTS			
Recommended Order Qty.:	Qty. Per Assembly:	Part Description:	Part Number:
1	1	Main filter media (sock)	CD-FILTER-BAG
1	1	Inlet strainer cartridge	3260.02
1	1	Pump seal kit	04-KIT UD-139
1	1	Pump valve kit	04-KIT UD-142
1	1	Pump brass kit	04-KIT UD-140
1	1	Pump plunger rod O-ring kit	04-KIT UD-141
1	1	Pressure regulating unloader repair kit	UB
1	1	Trigger valve repair kit – small gun	202700490
1	1	Trigger valve repair kit – large gun	203300490