



# ***CAVIBLASTER***<sup>®</sup>

**CAVIDYNE LLC**

5077 Fruitville Road  
Suite 109 - 157  
Sarasota, FL 34232 USA

Phone: (352) 275-5319  
[www.caviblast.com](http://www.caviblast.com)

# **Operation & Maintenance Manual**



**Model 2022-E**



CAVIDYNE LLC is not responsible for damages or injuries resulting from a failure to comply with instructions in this manual. Please read entire manual carefully before use.



The CaviBlaster 2022-E must only be operated and maintained by trained personnel.



This equipment generates high pressure water and is intended for underwater use only. **Serious personal injury or death may result from improper use.**



Commercial Diver's gear should be used to operate the CaviBlaster system.



Electric shock can cause severe burns or death. Ground system before connecting power supply. Use dedicated circuit installed by a licensed electrician. Circuit should supply adequate voltage and amperage under load.

# TABLE OF CONTENTS

<b>1.0 UNIT SPECIFICATIONS.....</b>	<b>5</b>
<b>2.0 GENERAL DESCRIPTION.....</b>	<b>6</b>
<b>2.1</b> Using this manual .....	8
<b>2.2</b> Conventions.....	8
<b>2.3</b> Scope .....	9
<b>2.4</b> Terms and Abbreviations.....	9
<b>3.0 SAFETY INFORMATION .....</b>	<b>11</b>
<b>3.1</b> Personal Safety .....	11
<b>3.2</b> Personal Protective Equipment .....	12
<b>3.3</b> Modification to the Equipment.....	13
<b>4.0 INSTALLATION .....</b>	<b>14</b>
<b>4.1</b> Uncrating and Lifting.....	14
<b>4.2</b> Installation Location.....	15
<b>4.3</b> Initial Set-Up .....	16
4.3.1 Connecting the Water Source.....	16
<b>5.0 OPERATION .....</b>	<b>20</b>
<b>5.1</b> Preparing the CaviBlaster for Operation.....	20
<b>5.2</b> Startup of the CaviBlaster.....	20
<b>5.3</b> Normal Operation.....	22
<b>5.4</b> Adjusting the CaviBlaster for Maximum Performance.....	22
<b>5.5</b> Recommendations for Effective Results .....	25
<b>6.0 MAINTENANCE.....</b>	<b>28</b>
<b>6.1</b> Basic Preventive Maintenance Recommendations .....	29
<b>6.2</b> Pump Service .....	29
<b>6.3</b> Inspection/Cleaning of Water Inlet Strainer.....	30
<b>7.0 WINTERIZATION.....</b>	<b>31</b>
<b>8.0 TROUBLESHOOTING.....</b>	<b>32</b>
<b>9.0 REPLACEMENT PARTS .....</b>	<b>34</b>
<b>APPENDIX - COMPONENT LITERATURE.....</b>	<b>35</b>

## LIST OF FIGURES & TABLES

<i>Figure 1.1 – CaviBlaster 2022-E60 Specifications.....</i>	<i>5</i>
<i>Figure 1.2 – CaviBlaster 2022-E50 Specifications.....</i>	<i>5</i>
<i>Figure 2.1 – CaviBlaster 2022-E General Features.....</i>	<i>7</i>
<i>Figure 2.2 – CaviBlaster 2022-E Control Panel.....</i>	<i>8</i>
<i>Figure 4.1 – Lifting Guidelines.....</i>	<i>14</i>
<i>Figure 4.2 – Installation Guidelines.....</i>	<i>15</i>
<i>Figure 4.3 – Gravity Feeding Source.....</i>	<i>17</i>
<i>Figure 5.2 – Zero-Thrust Gun Pressure Calibration.....</i>	<i>24</i>
<i>Figure 5.3 – Zero-Thrust Gun Position for Best Results.....</i>	<i>26</i>
<i>Figure 6.1 – Inspection / Cleaning Water Filter.....</i>	<i>30</i>

**This space intentionally left blank**

## 1.0 UNIT SPECIFICATIONS

The CaviBlaster 2022-E power unit consists of a 40HP (29.9 kW) electric motor and a AR-RTX-100.120 N plunger pump.

Detailed performance and specifications are listed below:

<b>CaviBlaster 2022-E/60 Specifications</b>	
Nominal Pump Flow	24.6 GPM (93 LPM)
Nozzle Operating Pressure	2,200-PSI (151 BAR)
Motor	40 HP 3PHASE 230/460V @ 60Hz
Installation Environment	Indoor or Outdoor <i>See Section 4 for installation requirements</i>
Water Inlet Pressure Limits	0-PSI (Atmospheric Pressure) to <b>50-PSI Maximum</b> (0 BAR to <b>3.5 BAR</b> ) <i>See Section 4 for further requirements</i>
Overall Unit Dimensions (L x W x H)	50" x 40" x 42" (127 cm x 101 cm x 107 cm)
Maximum Pressure Hose Length	300 LF (100 meters) of 3/4" diameter thermoplastic
Power Unit Weight (Dry)	1,225 LBS (557 KG)
Zero-Thrust Gun Weight	11 LBS (5 KG)

Figure 1.1 – CaviBlaster 2022-E60 Specifications

<b>CaviBlaster 2022-E/50 Specifications</b>	
Nominal Pump Flow	24.6 GPM (93 LPM)
Nozzle Operating Pressure	2,200-PSI (151 BAR)
Motor	40 HP 3PHASE 230/460V @ 50Hz
Installation Environment	Indoor or Outdoor <i>See Section 4 for installation requirements</i>
Water Inlet Pressure Limits	0-PSI (Atmospheric Pressure) to <b>50-PSI Maximum</b> (0 BAR to <b>3.5 BAR</b> ) <i>See Section 4 for further requirements</i>
Overall Unit Dimensions (L x W x H)	50" x 40" x 42" (127 cm x 101 cm x 107 cm)
Maximum Pressure Hose Length	300 LF (100 meters) of 3/4" diameter thermoplastic
Power Unit Weight (Dry)	1,225 LBS (557 KG)
Zero-Thrust Gun Weight	11 LBS (5 KG)

Figure 1.2 – CaviBlaster 2022-E50 Specifications

## 2.1 GENERAL DESCRIPTION

---

The CaviBlaster 2022-E high-pressure water power unit is designed to use water flow and pressure to generate cavitation at the end of the proprietary nozzle.

The CaviBlaster cleans the surface of any underwater structure using the energy released by the implosion of the bubbles created during the cavitation process. When directed at the surface being cleaned, the energy released by the collapsing bubbles causes marine growth to be removed from the surface.

The system consists of a portable, zero-thrust gun, connecting high-pressure hose and an electric motor-powered, high-pressure pumping unit. The zero-thrust gun uses a trigger-operated valve to control the water stream off and on. If the valve is closed, the power unit goes into bypass mode unloading the engine and the pump.

The CaviBlaster 2022-E power unit is a complete “plug and play” system built into a self-supporting frame that allows quick deployment and/or installation of the unit. Water can be supplied from either a pressurized source, directly from the natural source via an electric booster pump supplied with the power unit, or from a gravity feed storage tank.

The unit is equipped with many features to maintain operator safety while operating at pressures of 2,200-psi (151 bar).



***For more information on the CaviBlaster™ system please visit us at:***

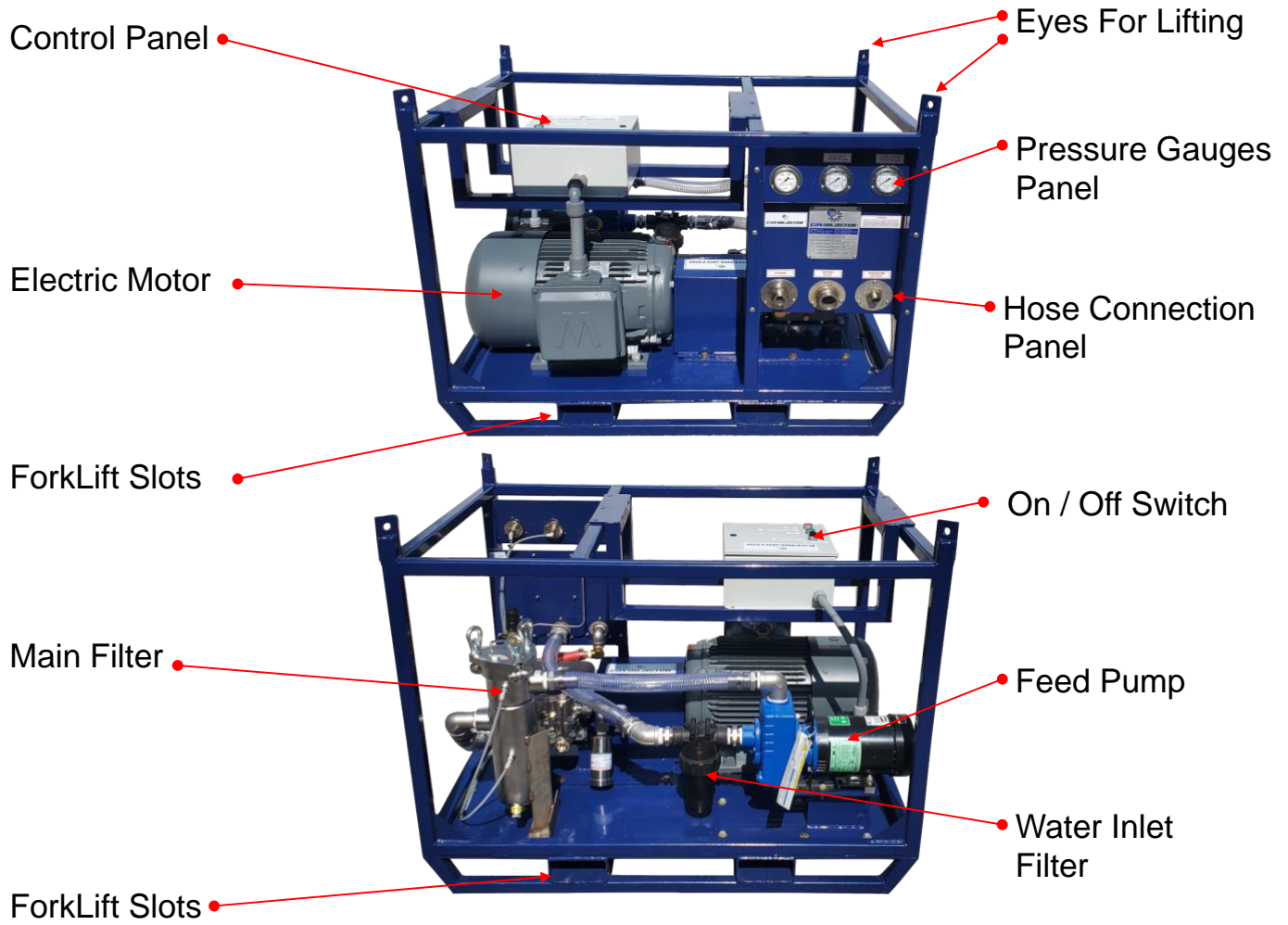
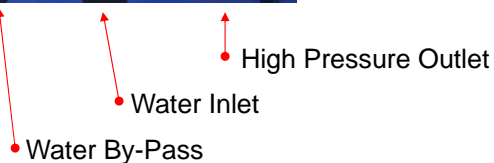
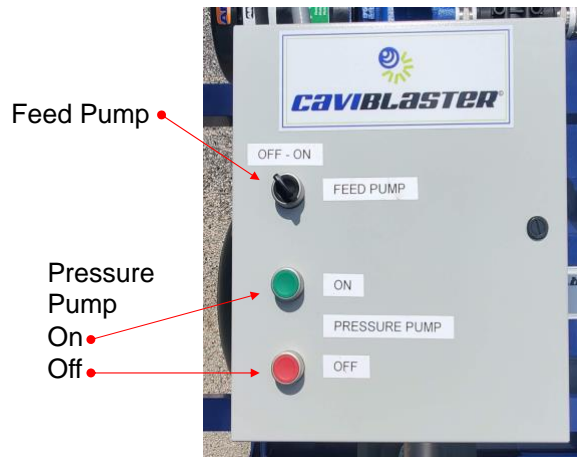

Figure 2.1 – CaviBlaster 2022-E General Features

## Pressure Control



## Main Control



*Figure 2.2 – CaviBlaster 2022-E Control panel*

## 2.2 Using this manual

Every attempt has been made to ensure that this documentation is complete and accurate at the time of publication. It is imperative; however, that anyone attempting to use this manual must have good comprehension of how this equipment operates. Further, this manual can in no way replace the common sense of an individual. If at any time this manual seems to contradict itself, or common sense, discontinue the procedure, re-read the section, and seek assistance from CaviDyne or other personnel familiar with the operation of this equipment.

## 2.3 Conventions

The first time a component is mentioned, it is typically followed by a figure reference; e.g., Emergency Stop button (See Figure 2.1). Figure numbers and section numbers are always coincident.



When other sections are referenced the *SECTION NAME* will appear in italic caps. The electronic version allows users to click on the section name or figure reference to jump to that section. The words “**This space intentionally left blank**” will appear where there is more than 3 inches of white space.

**(EOS)** will appear above the page number on the last page of each section.

## 2.4 Scope

This manual covers installation, operation, and maintenance of the CaviBlaster 2022-E. It is essential that personnel who will operate and/or service this equipment familiarize themselves with this manual. Standard components, such as the unit engine and pump, are covered by the manufacturer’s literature found in the Appendix.

## 2.5 Terms and Abbreviations

CCW	Counterclockwise
CW	Clockwise
EOS	End of Section
GPM	Gallons Per Minute
HP	Horsepower
LPM	Liters Per Minute
PPE	Personal Protective Equipment
PSI	Pounds Per Square Inch (without suffix, assumed to be gauge pressure).

**(EOS)**

### 3.1 SAFETY INFORMATION

---

The CaviBlaster 2022-E power unit is an inherently powerful and potentially dangerous piece of equipment; however, with proper care and training it can be operated safely. The 2022-E must only be operated by personnel that have read and understand this manual. It is intended to reinforce and review safety techniques to prevent personal injuries and property damage.

Users must comply with all local, state, and national laws concerning high-pressure water jetting equipment as well as all underwater work regulations.

It is strongly recommended that this entire manual be reviewed in-depth before operating or servicing this equipment. Service work should only be performed by individuals who are proficient in using this equipment. Refer to the applicable section in this manual for the correct procedures prior to any installation, setup, or maintenance work.

### 3.2 Personal Safety

Operation of the CaviBlaster 2022-E underwater cleaning system must only be attempted by commercial divers or other personnel who have been trained in its use. Appropriate protective equipment should always be worn. Operation of the system without the proper equipment and training can result in personal injury.



CaviDyne LLC is not responsible for damages resulting from a failure to comply with instructions in this manual. Please read carefully before use.



If maintenance or repair of the CaviBlaster zero-thrust gun is being conducted out of the water, remember that the zero-thrust gun has front and rear jets. Never direct the jet streams at a person or animal. Never direct the jet streams toward power lines or other high voltage equipment.



Ensure that there is a safe area to work while operating the CaviBlaster™ 2022-E.



Seek immediate medical attention if the operator suffers an injury as the result of contact with the high-pressure water stream. **Serious personal injury can result from an untreated water injection wound.**

### 3.3 Personal Protective Equipment

Always wear appropriate Personal Protective Equipment (PPE) when operating this equipment.

If the diver is not wearing a diving helmet, hearing protection is recommended. CaviDyne™ suggest wearing vented earplugs, such as “Doc’s Proplugs” or equivalent, for diver hearing protection.

The operators of the CaviBlaster system should always wear neoprene or heavy rubber gloves to provide protection to the hands and, in particular, to the nails. The gloves will absorb most of the energy produced by bursting cavitation bubbles and prevent the cavitation bubbles from contacting the operators’ hands. The gloves will also protect operators’ hands from the initial shockwave when the zero-thrust gun is activated.



Failure to wear appropriate PPE may result in personal injury.

### 3.4 Modification to the Equipment

Do not make any unauthorized modifications or repairs to this equipment. Components used throughout this assembly were specifically designed or selected to safely meet the unique high-pressure requirements. Only replace parts with those recommended by or supplied by CaviDyne™. Any unapproved modifications will void the equipment warranty. Unauthorized modification or part substitution can result in serious personal injury or property damage.



**Unauthorized replacement of any part may lead to catastrophic equipment failure and serious personal injury.**

**This space intentionally left blank**

**(EOS)**

## 4.1 INSTALLATION

---

The CaviBlaster™ 2022-E must be installed in accordance with the requirements outlined below. The unit can be installed in a vehicle to allow for maximum mobility and flexibility.

### 4.2 Uncrating and Lifting

Unpack the equipment and inspect for damage. If damage is found, immediately contact CaviDyne™ and the shipping company. **If there are missing parts/spare parts, contact freight carrier or insurance company.** *If the unit will not be installed immediately, provide adequate indoor storage to protect against damage.*

The CaviBlaster™ power unit should be lifted from underneath the frame using the forklift channels or by using the lifting eyes provided on top of the frame. Verify that lifting equipment is rated for the weight listed in Section 1.0 *UNIT SPECIFICATIONS* and that the unit is stable before lifting.

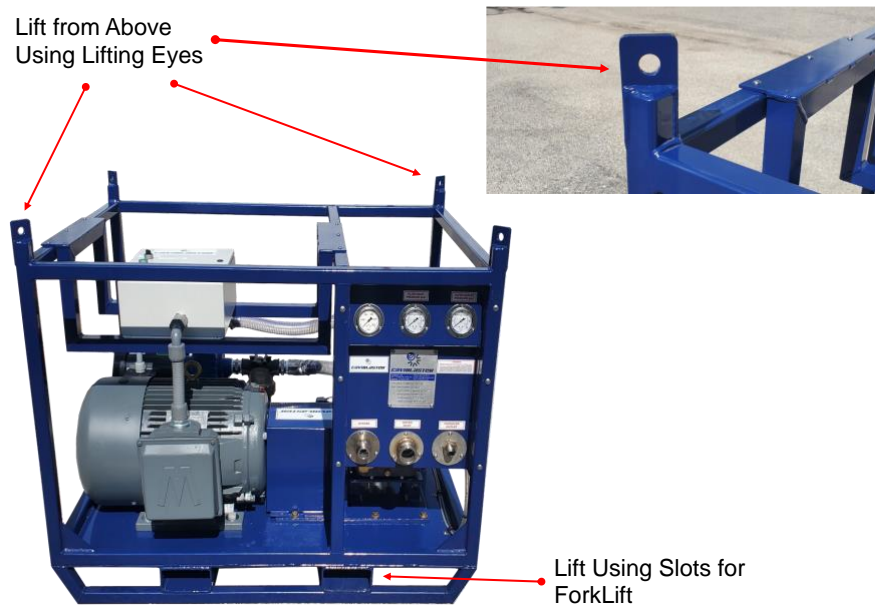

**Figure 4.1 – Lifting Guidelines**

### 4.3 Installation Location

For maximum flexibility the CaviBlaster power unit should be installed in an area where it is capable of reaching both its electric and water source and anticipated cleaning targets within acceptable power cable and hose lengths. The CaviBlaster power unit can be installed in an enclosed or open environment.

**\* Enclosed installations will require provisions for adequate motor cooling air flow. See Figure 4.2 below.**

Installation location must be a level surface able to safely support the unit weight listed in Section 1.0 *UNIT SPECIFICATIONS*. Orient unit to allow unrestricted access to the hose connection plate and control panel, located on the front of the unit. Allow a minimum of three feet behind the unit and access from above to conduct service and repair work. Take note of frequently serviced areas such as the in-line strainers and motor couplings.

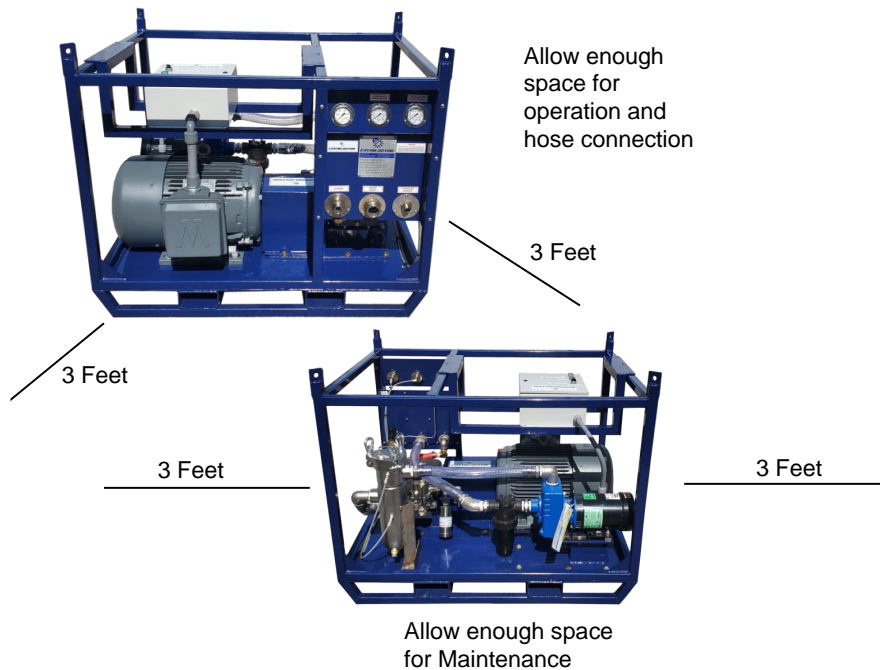

**Figure 4.2 – Installation Guidelines**

## 4.4 Initial Set-Up

After first receiving the CaviBlaster power unit, the following must be checked and completed:

- 1) Check/ Add pump oil (See Pump Manual located in the *APPENDIX*).
- 2) Push in the Emergency Motor Shut Down (E-Stop) button.
- 3) Turn the main power switch to the OFF position.
- 4) Turn the motor switch to the OFF position.
- 5) Turn the feed pump switch to the OFF position.
- 6) Connect the power cable supplied by customer for the unit to the power source.
- 7) Close and lock the control panel door.
- 8) Set the pump unload ball valve to the “OPEN” position.
- 9) Connect the feed or suction hose (See Section 4.3.2).
- 10) Connect the bypass hose (See Figure 2.2).
- 11) Connect the pressure hose (See Figure 2.2).



**Pump oil may have been removed for shipment. Check oil level prior to starting.**

### 4.3.1 Connecting the Water Source

The CaviBlaster power unit can be used with seawater or fresh water. It must be flushed with fresh water for 1-2 minutes after each use in seawater to ensure long service life.



**The CaviBlaster 2022-E must be flushed and rinsed with fresh water after every use in seawater.**



Failure to flush and rinse the power unit after use in seawater will result in increased wear and tear on components and in decreased service life.



Failure to flush and rinse the unit can cause the pump valve(s) to stick in the open position. This will prevent the system from producing the correct operating pressure.

The feed water inlet connection is located on the control panel (See Figure 2.2). An electric water pump is installed to provide positive inlet water pressure to the main pressure pump. Two water supply conditions are acceptable for the CaviBlaster™ power unit.

- Forced inlet water condition using the supplied electric water pump. An outside water source capable of supplying at least 30 GPM (114 L/m) at a **maximum pressure of 50-PSI (3.5 BAR)** is optional.
- Gravity feeding water source (See Figure 4.3). Use a hose with a diameter of at least 1-1/4" to connect the water tank to the power unit water inlet.



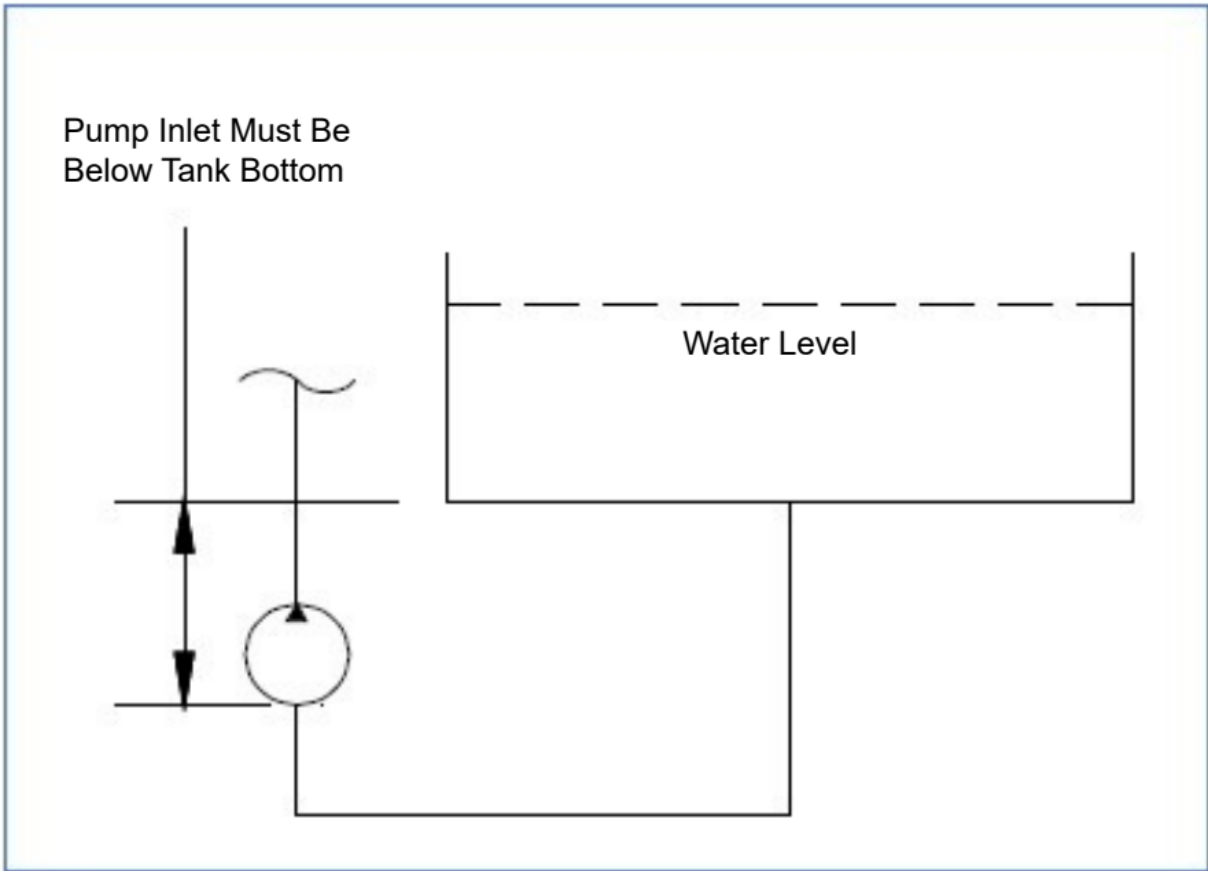

Figure 4.3 – Gravity Feeding Source

To use the feed pump supplied with the system:

- Turn the main power switch, motor switch and feed pump motor to OFF.
- Push IN the E-Stop button to ensure that the power supply has been disconnected. (See Figure 2.2).
- Turn the pump unload ball valve to the OPEN position.
- Connect the cam-lock socket on the 1-1/4" clear PVC feed hose to the water inlet connection on the control panel (See Figure 2.2). Place the other end of the hose in the water supply.

To use force feed from an alternate source:

- Turn the main power switch, motor switch and feed pump motor to OFF.
- Push IN the E-Stop button to ensure that the power supply has been disconnected. (See Figure 2.2).
- When feeding the CaviBlaster with an alternate water source, **the source must supply water at a volume of greater than 30 gallons per minute (114 L/m) at a maximum pressure of 50-psi.**
- Connect a 1-1/4" cam-lock socket on the water supply hose to the water inlet connection on the control panel (See Figure 2.2).
- Be certain the unit is properly primed prior to starting the main pump motor.

To use gravity feed:

- Locate the water supply tank so that the outlet of the tank is higher than the water inlet on the control panel (See Figures 2.2 and 4.3).
- Turn the main power switch, motor switch and feed pump switch to OFF
- Push IN the Emergency Motor Shut-Down button to ensure power has been disconnected. (See Figure 2.2).
- Connect a minimum 1-1/4" hose to the water inlet 1-1/4" cam-lock plug.
- Connect the other end of the hose to the water supply tank outlet.
- Open any valves installed in the water supply line.
- Make sure the lowest point in the hose line is the connection with the power unit.

- It is essential that adequate water is supplied to the water supply tank to maintain the water level several inches above the tank outlet. Failure to maintain an adequate water level in the supply tank could starve the pressure pump of water causing damage to the seals or other components of the pressure pump.

Ensure that the water source can reliably deliver the maximum pump flow of 20 GPM (76 L/m). A minimum flow of 30 GPM (114 L/m) is recommended to ensure that the pump is not starved of water. If connecting to a gravity feed tank, locate the tank outlet above the water inlet connection on the power unit to ensure a flooded suction line. (See Figure 4.3).



Ensure that the feed hose is connected to the inlet connection and the water supply is on prior to starting the pressure pump. Failure to supply water to the pressure pump will cause damage to the pump.

**(EOS)**

## 5.0 OPERATION

---

The CaviBlaster 2022-E should be operated by two (2) properly trained individuals. One, the diver, operates the zero-thrust gun, while the other operates the power unit. Both operators should be in audio or visual communication with each other.

**The CaviBlaster 2022-E should only be operated by properly trained personnel who are familiar with the contents of the manual. Review the safety requirements found in Section 3.0 before operating.**

### 5.1 Preparing the CaviBlaster for Operation

The following checklist should be completed in advance, so that the unit is always ready for immediate use. This should also be completed after each use.

- 1) Inspect the CaviBlaster power unit, electric power cord, hoses, JIC fittings and zero-thrust gun for any signs of damage.
- 2) Check that the motor is clean and ventilation openings are clear.
- 3) Inspect the inline strainer to ensure that it is not clogged (See Figure 6.1). Clean if necessary.
- 4) Check for proper pressure pump oil level (See pump Owner's Manual found in the *Appendix*). Add lubricating oil (SAE 30 non-detergent) if necessary.

### 5.2 Startup of the CaviBlaster

Before starting the CaviBlaster 2022-E power unit, review all safety requirements found in Section 3.0 *SAFETY INFORMATION*. This equipment should only be operated by individuals who have read and understand the CaviBlaster™ Operation and Maintenance Manual.

- 1) Verify that the unit has been properly prepared for operation as described in Section 4.
- 2) Unroll sufficient length of hose to reach the operating location and connect the zero-thrust gun to the high-pressure hose.
- 3) Ensure appropriate protective equipment (PPE) is worn by all personnel operating the unit. Once the unit is ready to commence cleaning operations, ensure that the zero-thrust gun is submerged in water.

*For more information email at [sales@cavidyne.com](mailto:sales@cavidyne.com) or call (352)275-5319*

- 4) Turn the E-Stop button and pull out to release (See Figure 5.1).
- 5) Turn the main power switch ON.
- 6) Turn the feed pump switch ON, the green light will turn on. Wait for feed pump to completely prime the system.
- 7) Turn the motor switch ON and wait for the blue light to turn on. Note that the motor is equipped with a “soft start” starter and may take 3-4 seconds for the motor to start after being turned ON.
- 8) **The diver and operators must wear neoprene or rubber gloves to protect the hands when operating the unit. Follow all safety regulations that may be applicable to the work being performed.**
- 9) With the zero-thrust gun submerged, pull the trigger to the open or ON position to release dead-headed pressure in unit while attempting start-up of the unit. Release trigger at once. (See figure 5.3)
- 10) The system is now ready to operate.



**DO NOT START THE MOTOR UNTIL THE DIVER IS READY FOR UNDERWATER OPERATION.**

### **5.3 Normal Operation**

Normal operation of the CaviBlaster system is defined as user control of water flow via the zero-thrust gun trigger. Control of the power unit from the zero-thrust gun trigger is accomplished by a mechanical shut-off valve in the zero-thrust gun. Should a problem develop with the control valve, discontinue using the CaviBlaster™ until fixed.



**Review the safety requirements for PPE and safe operation before proceeding.**

- 1) Startup the power unit as described in Section 5.2.
- 2) Activate the cleaning cavitation stream by squeezing the trigger to the open or “ON” position (See Figure 5.3). Release trigger to stop the water flow and direct to bypass.
- 3) If the diver operating the unit must be replaced or the cleaning operation must be interrupted or terminated, turn the unit off **and then release the water pressure in the hose(s) by squeezing the zero-thrust gun trigger to the open or “ON” position (See Figure 5.3) while under water.** Revert back to step 5.2 of the operating instructions when the diver or replacement is ready to continue cleaning.



**Although the CaviBlaster system is safe to use when submerged in water, the system generates a high-pressure (up to 2,200-psi [151 bar]) water stream, which can cause injury when the zero-thrust gun is out of the water. ALWAYS keep the zero-thrust gun submerged when the pressure pump is running.**

## **5.4 Adjusting the CaviBlaster for Maximum Performance**

The pressure at the nozzle of the zero-thrust zero-thrust gun has to be maintained within certain limits to achieve cavitation and for best performance results. If using a calibration pressure gauge situated between the pressure hose and the

CaviBlaster zero-thrust gun, (See Figure 5.2) the water pressure should be 2,200-psi (151 bar) with the zero-thrust gun submerged and the zero-thrust gun trigger in the open or “ON” position. For best results, repeat this calibration procedure if cleaning performance degrades, or every 3 months at a maximum.



A CALIBRATION GAUGE IS RECOMMENDED WITH EVERY UNIT. CONNECT BETWEEN THE END OF THE THERMOPLASTIC HOSE AND THE WHIP HOSE OR ZERO-THRUST GUN. SEE FIGURE 5.2.

To calibrate the pressure at the zero-thrust gun, follow the procedure below:

- Stop the power unit and pull the zero-thrust gun trigger to discharge any residual pressure in the hose lines.
- Disconnect the zero-thrust gun with its whip hose from the main pressure hose line.
- Attach the calibration gauge to the main pressure hose line and reattach the whip hose to the pressure gage. Tighten the JIC connections.
- Submerge the zero-thrust gun because of the danger of the operator coming in contact with either of the water streams from the cavitating or zero-thrust nozzles, **CaviDyne does NOT recommend calibrating the zero-thrust gun out of the water. Use extra care to avoid both water streams if doing so.**
- Ensure that both the cavitation and zero-thrust nozzles are pointed away from the diver's or operator's hands, arms and body.
- Start the power unit (See Section 5.2).
- Pull the zero-thrust gun trigger to the open or "ON" position (See Figure 5.3).
- Hold the zero-thrust gun tight and observe the calibration gauge (See Figure 5.2).
- The power unit operator should turn the knob on top of the pressure regulating valve until pressure reads 2,200-psi (151 bar) on the calibration gauge. Turning the knob clockwise will increase the pressure and turning it counter clockwise will decrease the pressure.

To calibrate the pressure at the CaviBlaster power unit, the water pressure at the power unit will need to be higher to account for sidewall friction loss in the pressure hose. The pressure at the pump should be 2,200-psi (151 BAR) plus 0.5- psi per foot (0.11 BAR per meter) of thermoplastic pressure hose. For example, if using the CaviBlaster with 100 feet (30 meters) of pressure hose, the pressure gauge located next to the pump should indicate 2,250-psi (155 bar). Pressure adjustments are made by turning the knob on top of the pressure regulating valve in the same manner as described above.



DO NOT ADJUST THE PRESSURE AT THE ZERO-THRUST GUN TO MORE THAN 2,200-PSI. HIGHER PRESSURE WILL NOT IMPROVE PERFORMANCE.



PUMP AND HOSES ARE RATED FOR 2,500-PSI. PRESSURES ABOVE 2,500-PSI COULD RESULT IN PUMP AND / OR HOSE FAILURE.

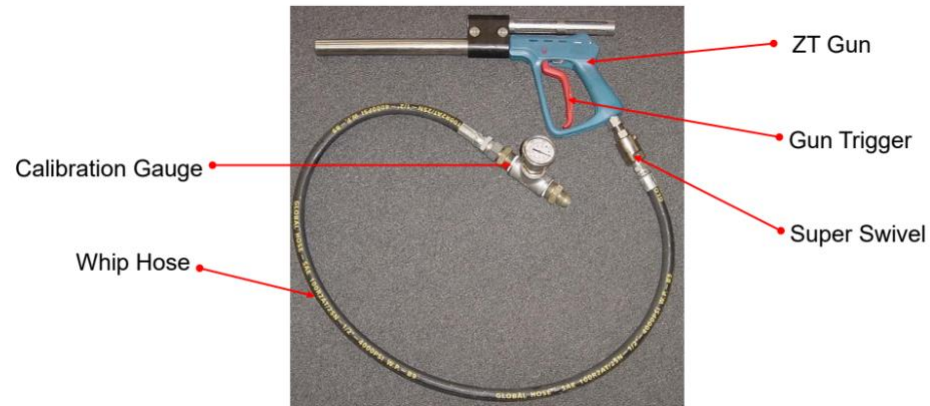
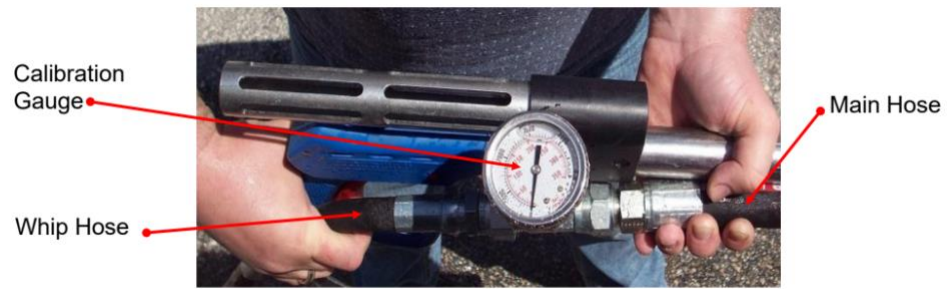

Figure 5.2 – Zero-thrust gun Pressure Calibration



## 5.5 Recommendations for Effective Results

Once the unit is operating at normal speed and the zero-thrust gun trigger is pulled, the diver has to find the most effective distance between the zero-thrust gun nozzle and the surface being cleaned.

When the diver is ready to commence cleaning operations, ensure that the zero-thrust gun trigger is in the open or “ON” position (See Figure 5.3), the zero-thrust gun is submerged in the water and the feed pump is operating prior to starting the electric motor. Ensure that the power unit operator and other people working in the vicinity of the power unit wear appropriate hearing protection when the unit is running.

1. Engage the pressure pump by turning the start-up by-pass valve to the “CLOSED” position (See Figure 5.1).
2. The most efficient operating technique is to hold the nozzle 2-5 inches (5-8 cm) away from the surface to be cleaned and at a 25 to 45 degree angle to the surface being cleaned (See Figure 5.3). The diver needs to observe the shape of the cavitating jet cone. At greater depths, the higher ambient pressure will cause the jet cone to be shorter. The widest zone of the cone is the most efficient part of the cavitating jet. Placing the nozzle closer than 2 inches (5 cm) from the surface being cleaned will not allow for efficient cavitation performance and will degrade the cleaning capability of the CaviBlaster system.
3. Follow all safety regulations that may be applicable to the work being performed.
4. If the diver operating the unit must be replaced or the cleaning operation must be interrupted or terminated, turn the unit off **and then release the water pressure in the hose(s) by squeezing the zero-thrust gun trigger to the open or “ON” position (See Figure 5.3) while under water.** Revert back to step 5.2 of the operating instructions when the diver or replacement is ready to continue cleaning.

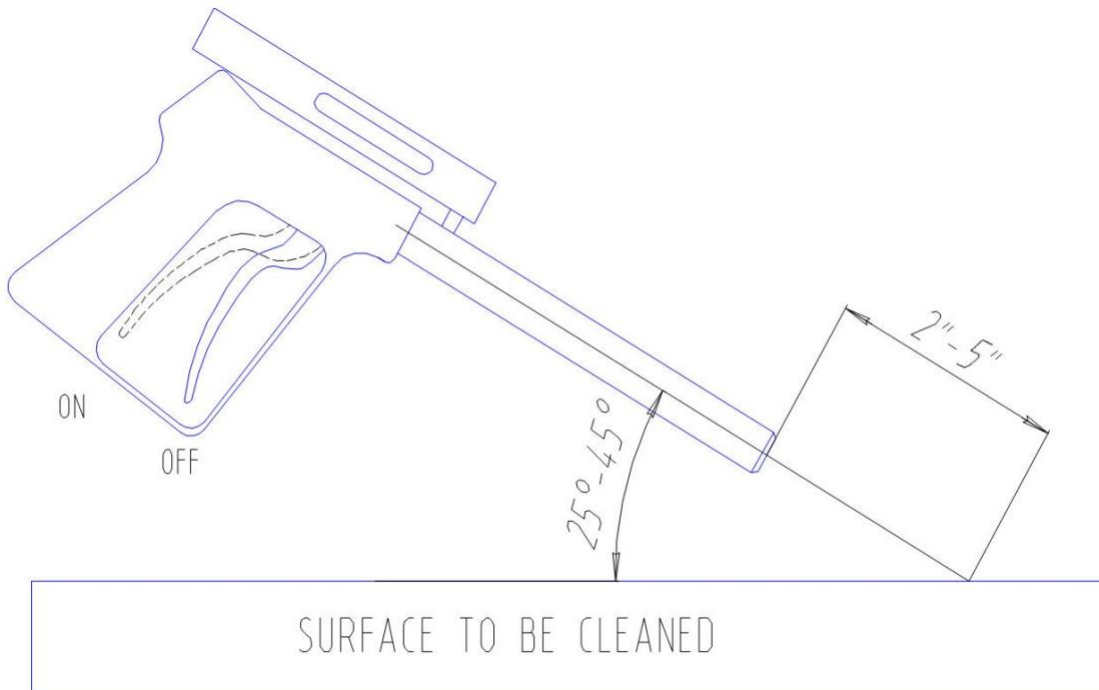

*Figure 5.3 – Zero-thrust gun Position for Best Results*



**CAUTION: DO NOT USE IT TO CLEAN SENSITIVE SURFACES** as LED-Lights, Underwater Lights, Electronic Equipment, Etc.

## 5.6 Shutting Down the CaviBlaster

1. Stop the motor by turning the motor switch to the OFF position (See Figure 2.2).
2. Turn the feed pump switch to the OFF position (See Figure 2.2). If using force feed from an alternate source or if using gravity feed, shut off the supply of water to the pressure pump.
3. Turn the main switch to the OFF position.
4. Push in the E-Stop button.
5. Squeeze the zero-thrust gun trigger to the open or “ON” position (See Figure 5.3) to release the water pressure remaining in the hose(s) **while the zero-thrust gun is submerged.**
6. It is now safe to remove the zero-thrust gun from the water.
7. Flush the system and rinse the power unit with fresh water at the end of the day if the system has been used with seawater.

**This space intentionally left blank**

(EOS)

## 6.0 MAINTENANCE

---

Maintenance on this unit should be restricted to authorized personal that have been properly trained. Review this manual, especially Section 3.0 *SAFETY INFORMATION*, prior to performing any service on this equipment.



Equipment must be OFF and pressure released from all hoses prior to performing any service work.



Only replace parts with those supplied or approved by CaviDyne LLC. Use of any other parts may lead to equipment failure and severe personal injury.



CAVIBLASTER MUST BE FLUSHED AND RINSED WITH FRESH WATER AFTER EACH USE IN SEA WATER.



FAILURE TO FLUSH AND RINSE THE UNIT WILL RESULT IN PREMATURE WEAR AND TEAR ON THE COMPONENTS AND DECREASED SERVICE LIFE.



Failure to flush and rinse the unit can cause the pump valve(s) to stick in the open position. This will prevent the system from producing the correct operating pressure.

## 6.1 Basic Preventive Maintenance Recommendations

	Before and After Every Use	Every 6 Months or 125 Hours*	Every 6 Months or 500 Hours*	Every 12 Months or 500 Hours*	Every 1,000 Hours	Every 4 Years or 7,500 Hours*
Check pump oil level and add if low	X					
Check in-line strainer cartridge and clean if necessary	X					
Inspect hoses for wear or damage <sup>1</sup>	X					
Check zero-thrust gun trigger for leakage and repair if necessary <sup>2</sup>		X				
Check integrity of motor winding insulation with "megger" test			X			
Replace pump oil <sup>3</sup>				X		
Check pump valves and seals for wear & change if necessary					X	
Lubricate motor bearings with high grade ball or roller bearing grease						X

\* Whichever occurs first.

- 1) If any hose damage is found, replace hose immediately.
- 2) Remove zero-thrust gun from water with system at operating pressure and trigger in the closed or "OFF" position. If water is leaking out of barrel or handle, the valve is worn and should be replaced.
- 3) The initial oil change is after 50 hours of operation. See pump manufacturer's literature in the Appendix for additional recommendations.

## 6.2 Pump Service

The high pressure water pump requires minimal maintenance. The pump oil level should be checked on a regular basis. The pump crankcase holds 44 oz. (1.3 L) of SAE 30 viscosity non-detergent oil. See pump manufacturer's literature found in the *APPENDIX* for further information.

*For more information email at [sales@cavidyne.com](mailto:sales@cavidyne.com) or call (352)275-5319*

### 6.3 Inspection / Cleaning of Inlet Strainer & Main Filter

The water inlet strainer should be inspected before and after each use of the CaviBlaster 2022-E. To inspect and clean this strainer, follow the procedure below:

- 1) Isolate or disconnect the water source from the inlet connection to the power unit.
- 2) Unscrew the filter bowl from the filter housing (turn CCW) (See Figure 6.1).
- 3) Pull filter bowl down and remove the strainer.
- 4) Inspect the strainer and flush any debris clean with clean water.
- 5) Push strainer back into housing and push the bowl back onto filter housing.
- 6) Thread the bowl CW onto the housing nut to hand tighten.



01-Unscrew the top and pull case down



02-Pull case down to reveal filter



03-Check filter and clean if necessary



04-Place filter back in case and Push up and screw again



01-Unscrew and Remove 3 bow screws



02-Pull lid up to reveal filter



03-Check filter and change if necessary



04-Place filter back in case and screw top lid again

06-Secure the 3 bow screws

05-Place lid back



***Figure 6.1 – Inspection / Cleaning Water Filter***

(EOS)

## 7.0 WINTERIZATION

---

The power unit should be winterized if stored at temperatures below 32 degrees Fahrenheit (0 degrees Celsius).

Total system displacement with 100 ft of hose (optional): 4.3 gallons.  
Total system displacement without hose: 2.0 gallons.

To winterize the CaviBlaster 2022-E power unit:

1. Fill a 5 gallon or larger container with appropriate antifreeze solution.
2. Connect a 1-1/4 cam-lock socket with a minimum amount of 1-1/4" clear hose to the water inlet connection on the control panel (See Figure 2.2) and place the open end of the clear hose into the antifreeze solution.
3. Attach a minimal amount of pressure hose to the pressure connection on the control panel (See Figure 2.2) and direct the open outlet of the hose into the antifreeze tank.
4. Attach a minimum amount of hose to the start-up by-pass valve and place the open end into the antifreeze tank.
5. Open the start-up by-pass valve and start the unit and make sure the pump is primed.
6. Close the start-up by-pass valve and run the unit until antifreeze comes out of the open end of the pressure hose for 10 seconds.
7. Stop the unit and disconnect all hoses.

Following this procedure will ensure that all the critical system components exposed to water have been flushed with antifreeze.

**This space intentionally left blank**

**(EOS)**

## 8.0 TROUBLESHOOTING

---

### 1. MOTOR WILL NOT START

- Usually caused by line trouble, such as single phasing at the starter
- Check sources of power
- Check overloads, fuses, controls, etc.

### 2. MOTOR HUMS EXCESSIVELY

- Check input line connections for high voltage
- Check for eccentric air gap

### 3. MOTOR OVERHEATS

- Overload – compare actual (measured) amps with nameplate rating  
Locate and remove source of excessive friction in motor or load
- Single phasing – check current at all phases (should be approximately equal to isolate and correct the problem
- Improper ventilation  
Check external cooling fan to ensure air is moving across cooling fins  
Excessive dirt build-up on motor – clean motor
- Unbalanced voltage - check voltage at all phases (should be approximately equal to isolate and correct the problem
- Rotor rubbing on stator  
Check air gap clearance and bearings  
Tighten “thru bolts”
- Over voltage or under voltage – check input voltage at each phase
- Open stator winding – check stator balance at all phases for balance
- Grounded winding – perform dielectric test and repair
- Improper connections – inspect all connections for proper termination, clearance, mechanical strength and electrical continuity

### 4. BEARING OVERHEATS

- Misalignment – check and align motor and pump
- Excessive end thrust from pump
- Excessive or insufficient grease in bearing – cavity should be  $\frac{3}{4}$  filled
- Dirt in bearing – clean bearing and cavity and refill approximately  $\frac{3}{4}$  full
- 

### 5. VIBRATION

- Misalignment – check and align motor and pump
- Rubbing between rotating and stationary parts
- Rotor out of balance
- Resonance – tune system



## 6. GROWLING OR WHINING

- Bad bearing – replace bearing and repack with correct grease

## 7. MOTOR RUNS, BUT WATER DOES NOT COME OUT OF THE ZERO-THRUST GUN

- Verify inlet water supply is functioning
- Ensure that the power unit is not located too far above the water level, exceeding the draw capacity of the feed pump
- Check that feed pump and inlet water strainers are clear
- Check for leaks in the water lines
- Check for an air-lock in the water inlet lines
- Verify that the feed pump is delivering water
  - Pump mechanical failure
  - Bad electrical connections
- Check that pressure pump inlet and discharge valves are not stuck open (common problem if not flushed after use with sea water)
- Check for water going out of the bypass – (regulating unloader failure)

## 8. WATER IN CRANK CASE

- Check the pump seals for damage (feeding water at greater than 50-psi (3.4 bar) can force water past the seals and damage the seals and starving the pressure pump of water can overheat and damage the seals)
- Check the plungers for cracks
- Check the plunger rod O-ring for damage

## 9. AFTER RELEASING THE MECHANICAL TRIGGER, WATER IS STILL LEAKING OUT OF THE ZERO-THRUST GUN

- Replace the mechanical trigger valve assembly in the zero-thrust gun handle

## 10. ZERO-THRUST GUN IS NOT CLEANING PROPERLY

- Verify that the system is operating at the correct pressure (2,000-psi)
- Remove the zero-thrust gun from water with the system at operating pressure and trigger in the closed or “OFF” position. If water is leaking out of the barrel or handle, the trigger valve assembly should be replaced.
- Check cavitation and zero-thrust nozzles for foreign particles

### **Visual inspection**

**With the unit turned OFF**, Insert a small wire into nozzle orifices to check for obstruction(s)

Remove trigger valve assembly and “back-flush” with compressed air or pressurized water

**(EOS)**

## 9.0 REPLACEMENT PARTS

---

<b>CaviBlaster 2022-E POWER UNIT REPLACEMENT PARTS</b>			
RECOMMENDED ORDER QTY	QUANTITY PER ASSEMBLY	PART DESCRIPTION	Part Number
1	1	Main Filter/Strainer Cartridge - SS	CD-CAR-0003
1	1	Inlet strainer cartridge	3260.02
1	1	Pump seal kit	UD-12
1	1	Pump valve kit	UD-93
1	1	Pump brass kit	UD-19
1	1	Pump plunger rod o-ring kit	UD-123
1	1	Pressure regulating unloader repair kit	UB 502 / K
1	1	Trigger valve repair kit – large gun	203300490

All parts can be  
ordered from:

### **CAVIDYNE LLC**

5077 Fruitville Rd Suite 109-157  
Sarasota, FL 34232 USA  
Phone: (352) 275-5319

Email: [support@cavidyne.com](mailto:support@cavidyne.com)

[www.caviblast.com](http://www.caviblast.com)

[www.cavidyne.com](http://www.cavidyne.com)

**(EOS)**

*For more information email at [sales@cavidyne.com](mailto:sales@cavidyne.com) or call (352)275-5319*

# APPENDIX - COMPONENT LITERATURE

---

<p><b>Worldwide Electric Motor Model WWE30-18-286TC</b></p>	<p>Motor Installation &amp; Maintenance Manual</p>
<p><b>AR Pump Model RTX 100.120 N</b></p>	<p>Pump Spec Sheet Pump Exploded View Pump Dimensions Pump Service Guide Pump Torque Specs</p>
<p><b>Udor Pressure Regulating Unloader Model UB402</b></p>	<p>Valve Spec Sheet</p>
<p><b>Suttner Small Trigger Gun Model ST-2720</b></p>	<p>Gun Schematic Drawing</p>

<p>Cavidyne Worldwide Electric Corp. Udor USA Suttner</p>	<p><b>Warranties</b></p>
---	--------------------------

**(EOS)**