

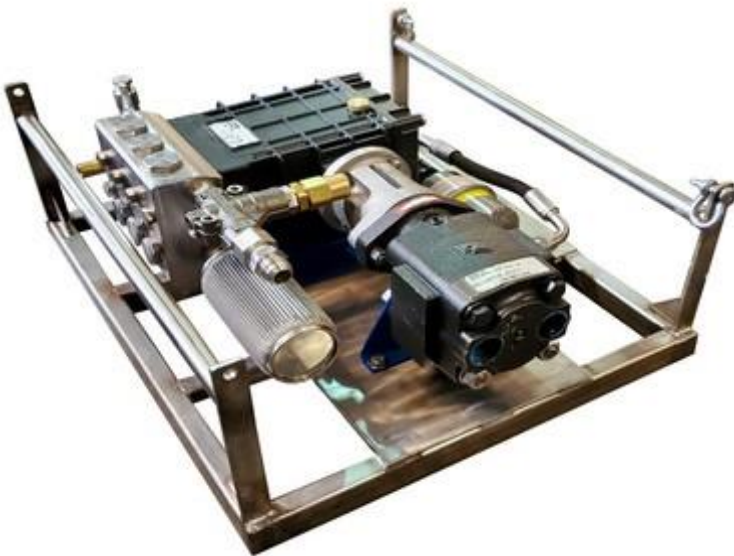

***CAVIBLASTER***<sup>TM</sup>

CAVIDYNE<sup>TM</sup>, LLC  
5077 Fruitville Rd., Suite  
109-157 Sarasota, FL 34232  
Phone: (352) 275-5319

# Operation & Maintenance Manual



**Model 1030-ROV**



CAVIDYNE LLC is not responsible for damages or injuries resulting from a failure to comply with instructions in this manual. Please read and study the entire manual carefully before use.



The CaviBlaster® 1030-ROV must only be operated and maintained by trained personnel.



This equipment generates high pressure water and is intended for underwater use only. **Serious personal injury or death and equipment / property damage may result from improper use.**

# TABLE OF CONTENTS

<b>1.0 UNIT SPECIFICATIONS.....</b>	<b>5</b>
<b>2.0 GENERAL DESCRIPTION.....</b>	<b>6</b>
2.1 Using this Manual .....	8
2.2 Conventions .....	8
2.3 Scope .....	8
2.4 Terms and Abbreviations .....	8
<b>3.0 SAFETY INFORMATION.....</b>	<b>9</b>
3.1 Personal Safety .....	9
3.2 Personal Protective Equipment.....	10
3.3 Modification to the Equipment.....	11
<b>4. 0 INSTALLATION .....</b>	<b>12</b>
4.1 Uncrating and Lifting.....	12
4.2 Initial Set-Up .....	13
<b>5.0 OPERATION .....</b>	<b>14</b>
5.1 Preparing the CaviBlaster® for Operation .....	14
5.2 Startup of the CaviBlaster® .....	15
5.3 Normal Operation .....	15
5.4 Adjusting the CaviBlaster® for Maximum Performance.....	16
5.5 Recommendations for Effective Results .....	19
<b>6.0 MAINTENANCE .....</b>	<b>21</b>
6.1 Basic Preventive Maintenance Recommendations .....	22
6.2 Pump Service.....	22
6.3 Inspection/Cleaning of Water Inlet Strainer .....	22
<b>7.0 TROUBLESHOOTING.....</b>	<b>23</b>
<b>8.0 REPLACEMENT PARTS.....</b>	<b>24</b>
<b>APPENDIX - COMPONENT LITERATURE.....</b>	<b>25</b>

## LIST OF FIGURES & TABLES

Figure 1.1 – CaviBlaster 1030-ROV Especifications .....	05
Figure 2.1 - CaviBlaster 1030-ROV General Features.....	07
Figure 4.1 – Lifting Guidelines .....	12
Figure 5.1 – Hydraulic Connections .....	17
Figure 5.2 – Lance Pressure Calibration .....	18
Figure 5.3 – Lance Position for Best Cleaning Results .....	19

**This space intentionally left blank**

## 1.0 UNIT SPECIFICATIONS

---

The CaviBlaster® 1030-ROV power unit consists of a 28HP (19 kW) Permco hydraulic gear motor power-pack and a UDOR GSC34/15 triplex plunger pump. Detailed performance and specifications are listed below:

<b>CaviBlaster® 1030-ROV Specifications</b>	
Nominal Pump Flow	17 GPM (65 LPM)
Nozzle Operating Pressure	3,000-PSI (207 BAR)
Driver	28 HP Hydraulic Gear Motor
Installation Environment	Submersible
Hydraulic Oil Flow Requirements	*See below.
Overall Unit Dimensions (L x W x H)	23-1/4" x 20" x 9-1/2" (59 cm x 50.8 cm x 23.1 cm)
Maximum Pressure Hose Length	300 LF (100 meters) of 1/2" (1.3 cm) diameter
Power Unit Weight (Dry)	131 LBS (54.5 KG)

*\*Hydraulic Power Unit must be capable of operating the water pressure pump at 1450 rpm and 21 HP. Consult CaviDyne regarding your existing Hydraulic Power Unit capabilities.*

Figure 1.1 – CaviBlaster® 1030-ROV Specifications

**This space intentionally left blank**

**(EOS)**

## 2.0 GENERAL DESCRIPTION

---

The CaviBlaster® 1030-ROV high-pressure water power unit allows the operator to use the water flow and pressure to generate cavitation at the end of the proprietary nozzle.

The CaviBlaster® cleans the surface of any underwater structure using the energy released by the implosion of the bubbles during the cavitation process. When directed at the surface being cleaned, the energy released by the collapsing bubbles causes marine growth to be removed from the surface.

The system consists of a portable high-pressure pumping unit designed for submersible ROV use and a high pressure cavitation lance (connected to ROV manipulator) with connecting high pressure hose.

The system is normally supplied with an integral pressure compensator, pressure compensation can also be achieved using the ROV onboard pressure system, consult with CaviDyne LLC for acceptable pressure compensations options.

The CaviBlaster® 1030-ROV power unit is a complete “plug and play” system built on a supporting platform that allows quick deployment and/or installation of the unit. Water is supplied directly from the unit operating environment.

The unit is equipped with many features to maintain safety while operating at pressures of 3,000-psi (207 bar).

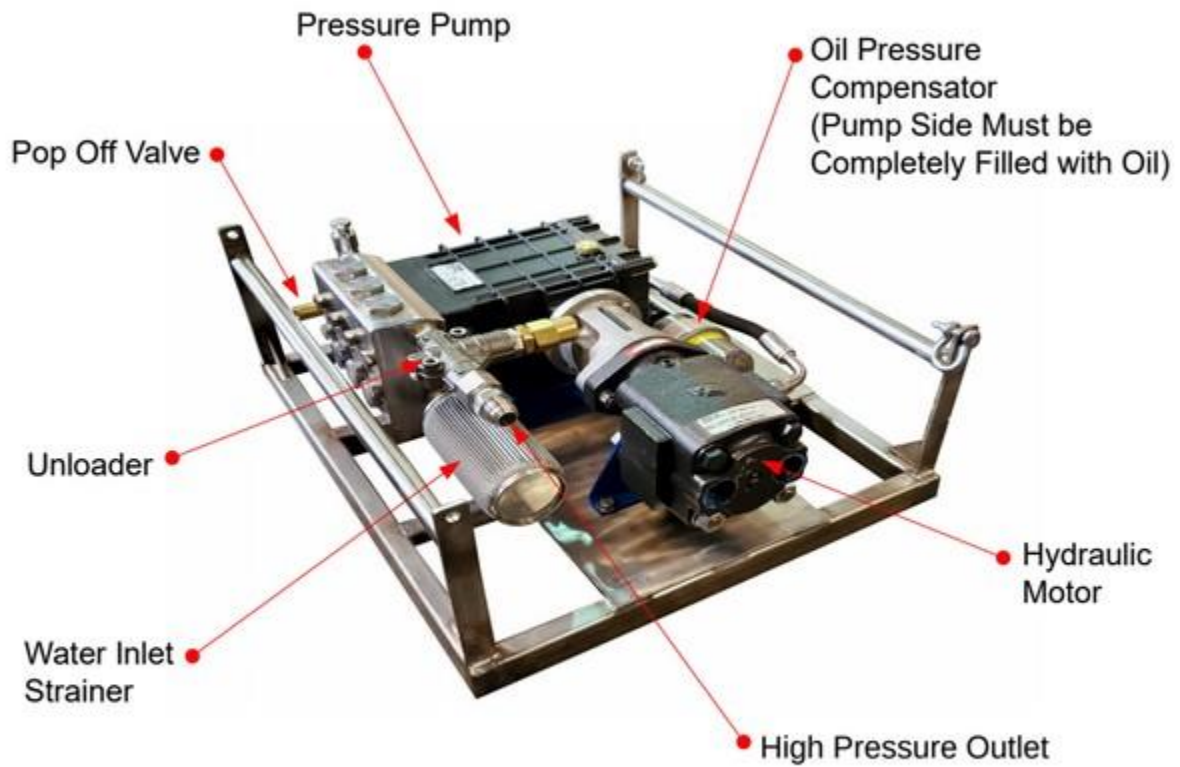

Figure 2.1 – CaviBlaster® 1030-ROV General Features

## 2.1 Using this Manual

Every attempt has been made to ensure that this documentation is complete and accurate at the time of publication. It is imperative; however, that anyone attempting to use this manual must have good comprehension of how this equipment operates. Further, this manual can in no way replace the common sense of an individual. If at any time this manual seems to contradict itself, or common sense, discontinue the procedure, re-read the section, and seek assistance from CaviDyne™ or other personnel familiar with the operation of this equipment.

## 2.2 Conventions

The first time a component is mentioned, it is typically followed by a figure reference; e.g., Emergency Stop button (See Figure 2.1). Figure numbers and section numbers are always coincident.

When other sections are referenced the *SECTION NAME* will appear in italic caps. The electronic version allows users to click on the section name or figure reference to jump to that section. The words “**This space intentionally left blank**” will appear where there is more than 3 inches of white space.

(EOS) will appear above the page number on the last page of each section.

## 2.3 Scope

This manual covers installation, operation, and maintenance of the CaviBlaster® 1030-ROV. It is essential that personnel who will operate and/or service this equipment familiarize themselves with this manual. Standard components, such as the unit engine and pump, are covered by the manufacturer’s literature found in the Appendix.

## 2.4 Terms and Abbreviations

CCW	Counterclockwise
CW	Clockwise
EOS	End of Section
GPM	Gallons Per Minute
HP	Horsepower
LPM	Liters Per Minute
PPE	Personal Protective Equipment
PSI	Pounds Per Square Inch (without suffix, assumed to be gauge pressure).



### 3.0 SAFETY INFORMATION

---

The CaviBlaster® 1030-ROV power unit is an inherently powerful and potentially dangerous piece of equipment; however, with proper care and training it can be operated safely. The 1030-ROV must only be operated by personnel that have read and understand this manual. It is intended to reinforce and review safety techniques to prevent personal injuries and property damage.

Users must comply with all local, state, and national laws concerning high-pressure water jetting equipment as well as all underwater work regulations.

It is strongly recommended that this entire manual be reviewed in-depth before operating or servicing this equipment. Service work should only be performed by individuals who are proficient in using this equipment. Refer to the applicable section in this manual for the correct procedures prior to any installation, setup, or maintenance work.

Note that the oil pressure compensator is not a pressurized component and therefore not a safety hazard. It is open at one end and connected to the pressure pump oil chamber at the other end. Its purpose is simply to balance the oil pressure in the water pressure pump with the unit's surrounding environmental pressure to prevent damage to the water pressure pump.

#### 3.1 Personal Safety

Operation of the CaviBlaster® 1030-ROV underwater submersible ROV-mounted cleaning system must only be operated by personnel who have been trained in its use. Operation of the system without the proper training can result in property damage and damage to the CaviBlaster® unit.





If maintenance or repair of the CaviBlaster® is being conducted out of the water, remember that the unit generates a high pressure water jet stream. Never direct the jet stream at a person or animal. Never direct the jet stream toward power lines or other high voltage equipment.



Ensure that there is a safe area to work while operating or maintaining the CaviBlaster® 1030-ROV.



Seek immediate medical attention if the operator suffers an injury as the result of contact with the high-pressure water stream. **Serious personal injury can result from an untreated water injection wound.**

### 3.2 Personal Protective Equipment

Always wear appropriate Personal Protective Equipment (PPE) when performing maintenance or calibration on this equipment.

Personnel operating or working in the vicinity of the power unit should wear appropriate hearing protection when the CaviBlaster® during maintenance or calibration procedures.

Personnel performing maintenance or calibration procedures on the CaviBlaster® 1030-ROV system should always wear neoprene or heavy rubber gloves to provide protection to the hands and, in particular, to the nails. The gloves will absorb most of the energy produced by bursting cavitation bubbles and prevent the cavitation bubbles from contacting the operators' hands. The gloves will also protect operators' hands from the initial shockwave when the lance is activated.



Failure to wear appropriate PPE may result in personal injury.

### 3.3 Modification to the Equipment

Do not make any unauthorized modifications or repairs to this equipment. Components used throughout this assembly were specifically designed or selected to safely meet the unique high-pressure requirements. Only replace parts with those recommended by or supplied by CaviDyne™. Any unapproved modifications will void the equipment warranty. Unauthorized modification or part substitution can result in serious personal injury or property damage.



Unauthorized replacement of any part may lead to catastrophic equipment failure and serious personal injury.

**This space intentionally left blank**

**(EOS)**

## 4. 0 INSTALLATION

---

The CaviBlaster® 1030-ROV must be securely attached to the ROV using the vibration mounts supplied or other secure fastening mechanism.

### 4.1 Uncrating and Lifting

Unpack the equipment and inspect for damage. If damage is found, immediately contact CaviDyne™ and the shipping company. *If the unit will not be installed immediately, provide adequate indoor storage to protect against damage.*

The CaviBlaster® power unit should be lifted from underneath. Do not use components of the CaviBlaster® to lift the entire unit.

Fig  
ure  
4.1  
=  
Lifti  
ng  
Gui  
deli  
nes

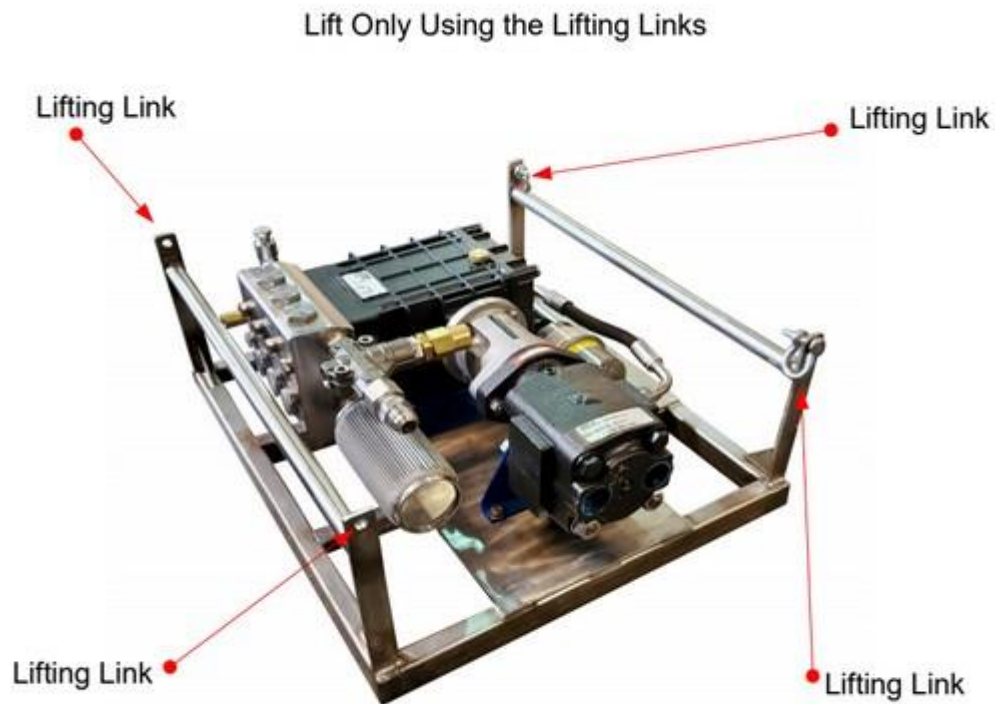

### Set-Up

After first receiving the CaviBlaster® power unit, the following must be completed:  
See Figure 2.1 for item locations.

1. Remove hose between pump and oil pressure compensator.
2. Add oil to pump by completely filling pump to top of fill port.
3. Reconnect hose to pump only.
4. Stand unit on end with pump at top, hold hose upright to prevent leakage.
5. Remove oil pressure compensator fill port cap.
6. Fill oil pressure compensator and hose with oil.
7. Reconnect hose to oil pressure compensator and allow unit to sit for several minutes to allow any trapped air to escape.
8. Top off oil pressure compensator as required.
9. Replace oil pressure compensator fill port cap.
10. Set unit back down on vibration mounts.
11. Connect hydraulic power unit hoses.
12. Connect water pressure hose.



Pump fluids may have been removed for shipment. Check ALL fluid levels prior to starting.



The CaviBlaster® 1030-ROV can be used with seawater but must be flushed and rinsed with fresh water after every use in seawater. Failure to flush and rinse the power unit after use in seawater will result in increased wear and tear on components and can cause the pump valve(s) to stick in the open position. This will prevent the system from producing the correct operating pressure.

**(EOS)**

## 5.0 OPERATION

---



The CaviBlaster® 1030-ROV should only be operated by properly trained personnel who are familiar with the contents of the manual. Review the safety requirements found in Section 3 before operating.

### 5.1 Preparing the CaviBlaster® for Operation

The following checklist should be completed in advance, so that the unit is always ready for immediate use. This should be completed after each use.

- 1) Inspect the CaviBlaster® power unit, hoses, JIC fittings and lance for any signs of damage.
- 2) Inspect the water inlet strainer to ensure that it is not clogged (See Figure 2.1). Clean if necessary.
- 3) Check for proper pressure pump oil level (See pump Owner's Manual found in the *Appendix*). Add oil (SAE 30 non-detergent) if necessary. **PUMP MUST BE COMPLETELY FILLED.**



Incorrect oils should not be used as they may damage the equipment.

### 5.2 Startup of the CaviBlaster®

Before starting the CaviBlaster® 1030-ROV unit, review all safety requirements found in Section 3.0 *SAFETY INFORMATION*. This equipment should only be operated by individuals who have read and understand the CaviBlaster® Operation and Maintenance Manual.

- 1) Verify that the unit has been properly prepared for operation as described in Section 4.
- 2) Verify that the lance is properly connected to the CaviBlaster® and the ROV.
- 3) Run the ROV hydraulic system to verify that the CaviBlaster® hydraulic motor and pressure pump are functioning correctly.

### 5.3 Normal Operation

Normal operation of the CaviBlaster® system is defined as user control of water flow via the lance. In the absence of a diver, control of the power unit is accomplished by the ROV manipulator. Should a problem develop with the control valve, discontinue using the CaviBlaster® until fixed.

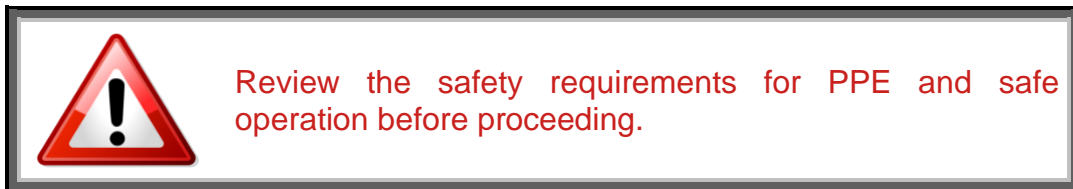

- 1) The ROV hydraulic system needs to be operating at a capacity that matches the water pressure pump requirements for the CaviBlaster® 1030-ROV to function correctly. Unlike gasoline or diesel engines, a hydraulic motor will run as fast as the oil supply it receives, which means that the hydraulic oil supply must be adjusted to match the water pressure pump requirements. Consult with CaviDyne LLC to determine if your high pressure oil supply unit is suitable for the CaviBlaster® 1030-ROV.  
**(Please see flow requirements in spec sheet attached at the appendix of this manual.)**
- 2) Activate the cleaning cavitation stream by turning ON the hydraulic power unit.



Although the CaviBlaster® system is safe to use when submerged in water, the system generates a high-pressure (up to 3,000-psi [207 bar]) water stream, which can cause injury when the lance is out of the water. **ALWAYS** keep the lance submerged when the pressure pump is engaged.

## 5.4 Adjusting the CaviBlaster® for Maximum Performance

The pressure at the nozzle of the lance has to be maintained within certain limits to achieve cavitation and for best performance results. If using a calibration pressure gauge situated between the pressure hose and the CaviBlaster® lance, the water pressure should be 3,000-psi (207 bar) with the lance submerged and the hydraulic power unit operating. For best results, repeat this calibration procedure if cleaning performance degrades, or every 3 months at a maximum.



**A CALIBRATION GAUGE IS RECOMMENDED WITH EVERY UNIT. CONNECT BETWEEN THE END OF THE HOSE AND THE LANCE.**

To calibrate the pressure at the lance, follow the procedure below:

- Stop the hydraulic power unit to discharge any residual pressure in the hose lines.
- Disconnect the lance from the main hose line.
- Attach the calibration gauge between the main hose line and the lance and tighten the JIC connections. (See figure 5.1)
- Submerge the lance. Because of the danger of the operator coming in contact the water stream from the cavitating nozzle, **CaviDyne does NOT recommend calibrating the lance out of the water. Use extra care to avoid the water stream if doing so.**
- Ensure that the cavitation nozzle is pointed away from the diver's or operator's hands, arms and body.
- Start the hydraulic power unit.
- Hold the lance tight and observe the calibration gauge.
- Turn the knob on top of the pressure regulating valve (See figure 5.1) until pressure reads 3,000-psi (207 bar) on the calibration gauge. Turning the knob clockwise will increase the pressure and turning it counter clockwise will decrease the pressure.



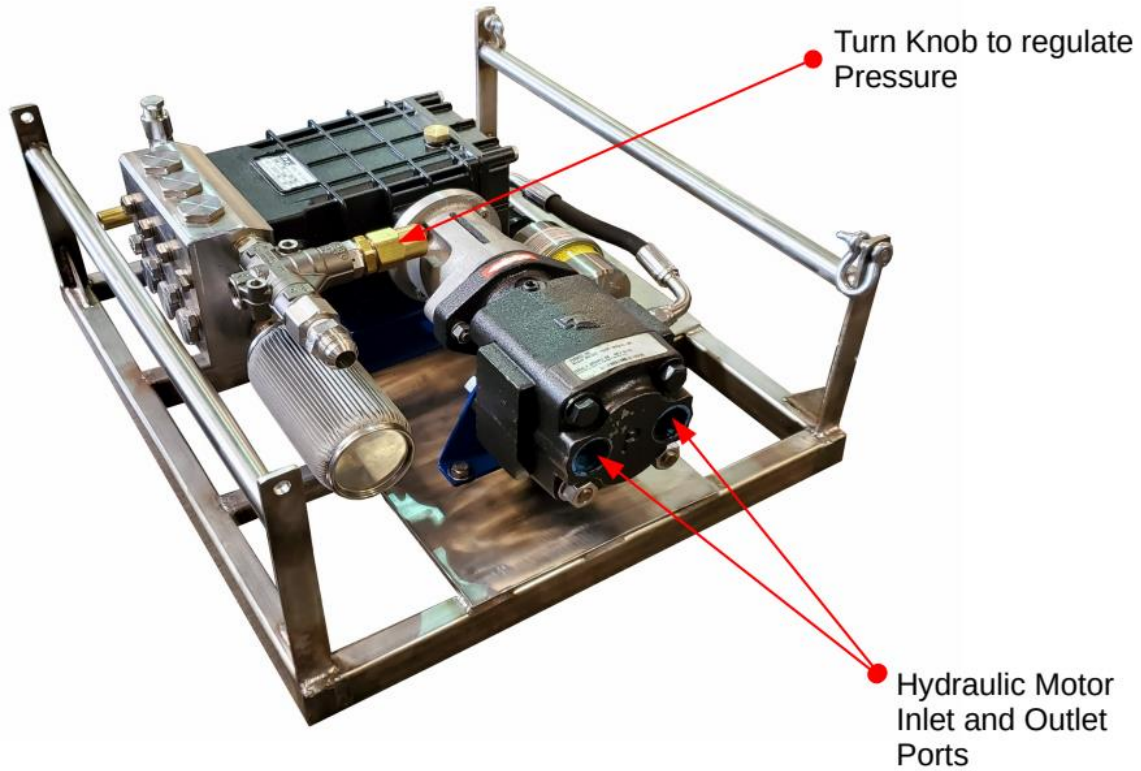

*Figure 5.1 – Hydraulic Connections*



DO NOT ADJUST THE PRESSURE AT THE LANCE TO MORE THAN 3,000-PSI (207 BAR). HIGHER PRESSURE WILL NOT IMPROVE PERFORMANCE AND COULD RESULT IN SERIOUS DAMAGE TO THE PUMP.



HOSES ARE RATED FOR 4,000-PSI (272 BAR) PRESSURES ABOVE 4,000-PSI (272 BAR) COULD RESULT IN HOSE FAILURE.

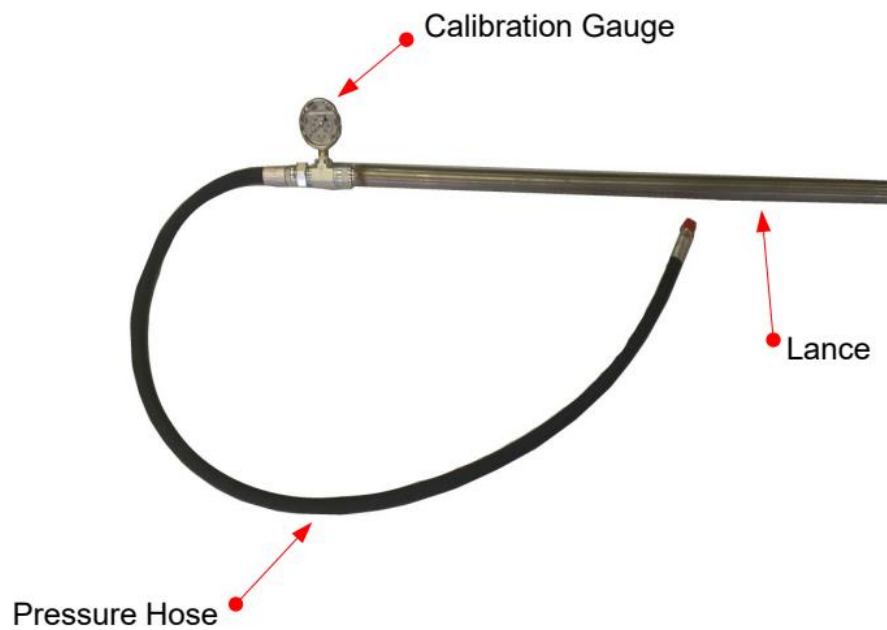

*Figure 5.2 – Lance Pressure Calibration*

## 5.5 Recommendations for Effective Results

When the ROV operator is ready to commence cleaning operations, verify that the lance is securely attached to the manipulator.

Once the hydraulic power unit is operational and the water jet stream is flowing from the lance, the ROV operator has to find the most effective distance between the lance nozzle and the surface being cleaned. (See Figure 5.3)

1. Engage the ROV's hydraulic power unit to activate the CaviBlaster® unit.
2. The most efficient operating technique is to hold the nozzle 2-5 inches (5-12 cm) away from the surface to be cleaned and at a 25 to 45 degree angle to the surface being cleaned (See Figure 5.3). The ROV operator needs to observe the shape of the cavitating jet cone. At greater depths, the higher ambient pressure will cause the jet cone to be shorter. The widest zone of the cone is the most efficient part of the cavitating jet. Placing the nozzle closer than 2 inches (5 cm) from the surface being cleaned will not allow for efficient cavitation performance and will degrade the cleaning capability of the CaviBlaster® system.
3. Follow all safety regulations that may be applicable to the work being performed.

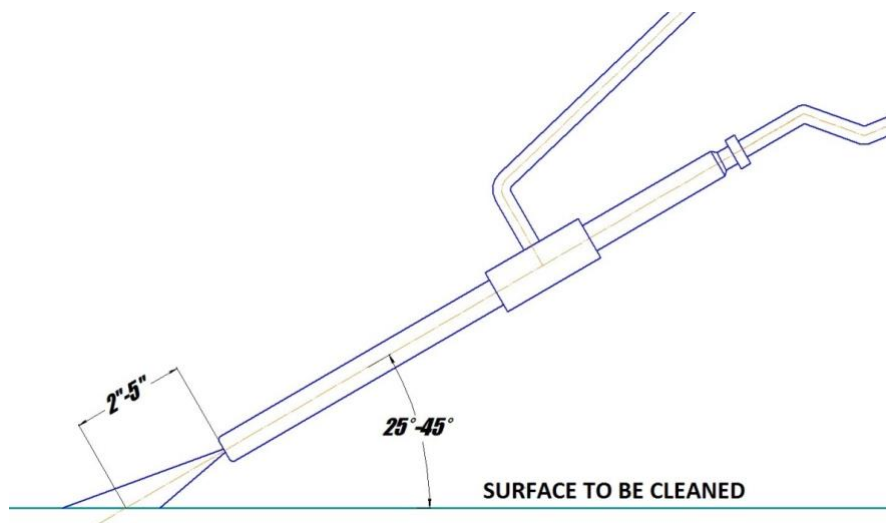

**Figure 5.3 – Lance Position for Best Cleaning Results**

## **5.6 Shutting Down the CaviBlaster® 1030-ROV.**

1. Shut down the ROV hydraulic power unit, this will turn off the pressure pump and relieve pressure in the system.
2. It is now safe to remove the lance from the water.
3. Flush the system and rinse the power unit with fresh water at the end of the day or work shift.

**This space intentionally left blank**

**(EOS)**

## 6.0 MAINTENANCE

---

Maintenance on this unit should be restricted to authorized personal that have been properly trained. Review this manual, especially Section 3.0 *SAFETY INFORMATION*, prior to performing any service on this equipment.



Equipment must be **OFF** and pressure released from all hoses prior to performing any service work.



Only replace parts with those supplied or approved by CaviDyne Use of any other parts may lead to equipment failure and severe personal injury.



CAVIBLASTER® MUST BE FLUSHED AND RINSED WITH FRESH WATER AFTER EACH USE IN SEA WATER.



FAILURE TO FLUSH AND RINSE THE UNIT WILL RESULT IN PREMATURE WEAR AND TEAR ON THE COMPONENTS AND DECREASED SERVICE LIFE.



Failure to flush and rinse the unit can cause the pump valve(s) to stick in the open position. This will prevent the system from producing the correct operating pressure.

## 6.1 Basic Preventive Maintenance Recommendations

	After Every Use	Every 6 Months or 125 Hours*	Every 12 Months or 250 Hours*	Every 12 Months or 500 Hours*	Every 1,000 Hours
Ensure pump and oil pressure accumulator are filled with oil	X				
Check water inlet strainer cartridge and clean if necessary	X				
Inspect hoses for wear or damage <sup>1</sup>	X				
Replace pump oil <sup>2</sup>				X	
Check pump valves and seals for wear & change if necessary					X

\* Whichever occurs first.

- 1) If any hose damage is found, replace hose immediately.
- 2) The initial oil change is after 50 hours of operation. See pump manufacturer's literature in the Appendix for additional recommendations.

## 6.2 Pump Service

The high pressure water pump requires minimal maintenance. The pump oil should be checked on a regular basis. The pump crankcase should be COMPLETELY FILLED with SAE 30 viscosity non-detergent oil. See pump manufacturer's literature found in the *APPENDIX* for further information.

## 6.3 Inspection/Cleaning of Water Inlet Strainer

The water inlet strainer should be inspected after each use of the CaviBlaster® 1030-ROV.

**(EOS)**

## 7.0 TROUBLESHOOTING

---

### 1. WATER IN CRANK CASE

- Check the pump seals for damage
- Check the plungers for cracks
- Check the plunger rod O-ring for damage
- Check oil pressure compensator bladder for damage

### 2. LANCE IS NOT CLEANING PROPERLY

- a. Remove the CaviBlaster® unit from the water and mount the lance securely in a vice or test stand. Make sure the lance is pointed away from any personnel and any electrical systems or components in the area. The water jet from the lance can travel 30 to 40 feet (9 to 12 meters).
- b. Connect the hydraulic motor to a hydraulic power unit and start the hydraulic power unit. Verify that the hydraulic power unit is delivering the correct RPM (1450) and HP (21) required to operate the water pressure pump.
- c. If water is leaking out of the hose, fittings or connections replace the damaged component and securely tighten all connections.
- d. If water is leaking from the lance body contact CaviDyne™ for further instructions.
- e. Check lance and nozzle for foreign particles;
  - Visual inspection
  - Insert a small wire into nozzle orifices to check for obstruction(s) and “back-flush” with compressed air or pressurized water.

**(EOS)**

## 8.0 REPLACEMENT PARTS

---

<b>CaviBlaster® 1030-ROV POWER UNIT REPLACEMENT PARTS</b>			
<b>RECOMMENDED ORDER QTY</b>	<b>QUANTITY PER ASSEMBLY</b>	<b>PART DESCRIPTION</b>	<b>PART NUMBER</b>
1	1	Water inlet strainer	CASS-20-1-100-316
1	1	Pump seal kit	UD-99
1	1	Pump valve kit	UD-116
1	1	Pump stainless kit	UD-117
1	1	Pump plunger rod o-ring kit	UD-119
1	1	Regulating unloader repair kit	UB 402 / K
1	1	Relief valve repair kit	UB 402 / K
1	1	Oil pressure compensator	S245A1QTTB3
1	1	Oil Fill Hose With Fittings	HD06-011-0-A106- SS
1	1	HytreI Spider	16624329-24/32

All parts can be  
ordered from:

### **CAVIDYNE™, LLC**

5077 Fruitville Rd.; Ste 109-157  
Sarasota, FL 34235 USA

Phone: (352) 275-5319

Email: [support@cavidyne.com](mailto:support@cavidyne.com)  
[www.caviblasters.com](http://www.caviblasters.com)

**(EOS)**



## APPENDIX - COMPONENT LITERATURE

---

<p><b>Permco Hydraulic Gear Motor</b></p>	<p>Spec Sheet - Permco 2100-3000</p>
<p><b>Udor Pump Model GSC34/15</b></p>	<p>Pump Spec Sheet            Pump Exploded View            Pump Dimensions            Pump Service Guide            Pump Torque Specs</p>
<p><b>Udor Pressure Regulating Unloader &amp; Relief Valve Model UB 402</b></p>	<p>Valve Spec Sheet</p>

<p>Cavidyne            Permco            Udor USA</p>	<p style="text-align: right;"><b>Warranties</b></p>
---	---

(EOS)



## CaviBlaster 1030-ROV

Remote Operated Vehicle, 10 gpm & 3,000 psi

### Specifications and Options

A compact and powerful submersible hydraulically driven cleaning system compatible with a wide range of ROVs available with different types of lances

#### Accessories Included:

Full forward thrust lance or balanced zero thrust lance



SKID Dimensions	
Length	20" / 50.8 cm
Width	23-1/4" / 59 cm
Height	9-1/2" / 23.1 cm
Weight	131 Lbs / 54.5 kg

Pump System	
Pressure Pump	Udor GSC34/15
Pump Material / Type	SS / Triplex plunger
Flow Rate	10 gpm / 38 Lpm
Nozzle Pressure	3,000 psi / 207 Bar
Hose Diameter	1/2"

Tools	
Tool Type	Lance

Drive System	
Drive System	Direct Drive
Manufacturer	Permco
Motor	Permco2100-3000
Size Cubic Inches	3.5 CIR
SH Flow - Pressure	22 gpm/84Lpm - 2,160psi/149Bar
AH Flow - Pressure	13gpm/49Lpm - 3,500psi/241Bar

Ideal For
Deep water operations
Piers, Pilings & Seawalls
Running gear & Out drivers

Shipping Dimensions	
Pallet 30x25x25"	140 Lbs Gross weight

\* Pricing and specifications subject to change without notice

CaviDyne LLC, 5077 Fruitville Rd. Suite - 109-157, Sarasota FL, 34232 USA  
 Phone: (352)275-5319, sales@cavidyne.com, www.cavidyne.com

